

C434

DOUBLE COLD FRAME Assembly instruction

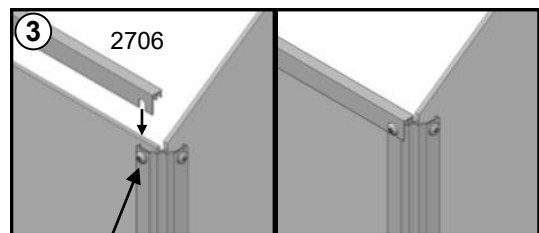

Screws and nuts installed first (not tighten) before top frame and PC panel inserted

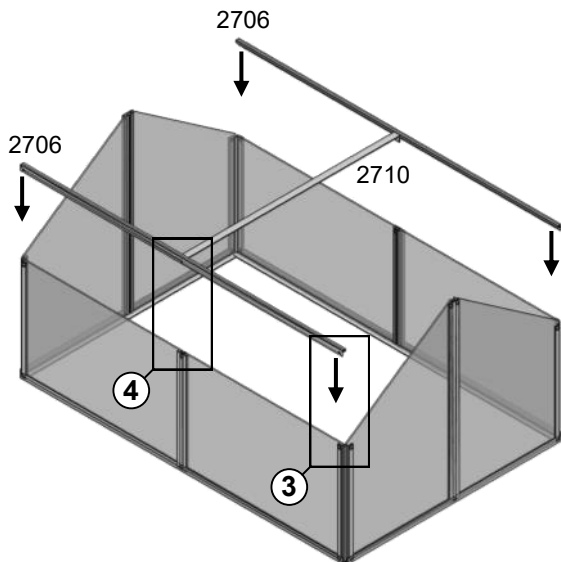
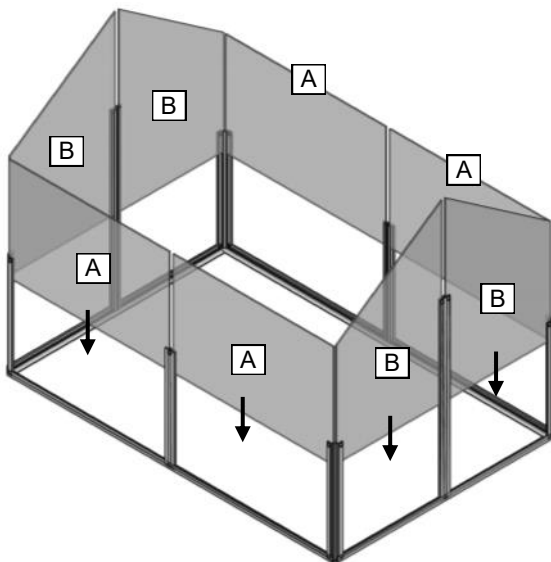
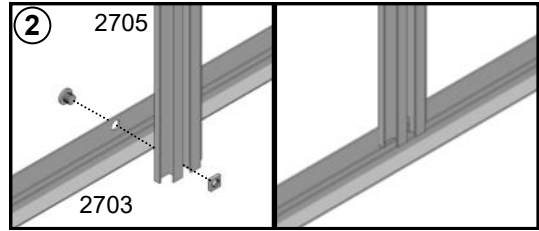
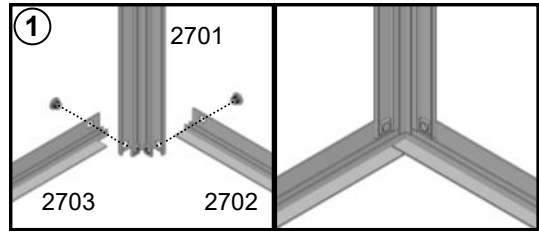
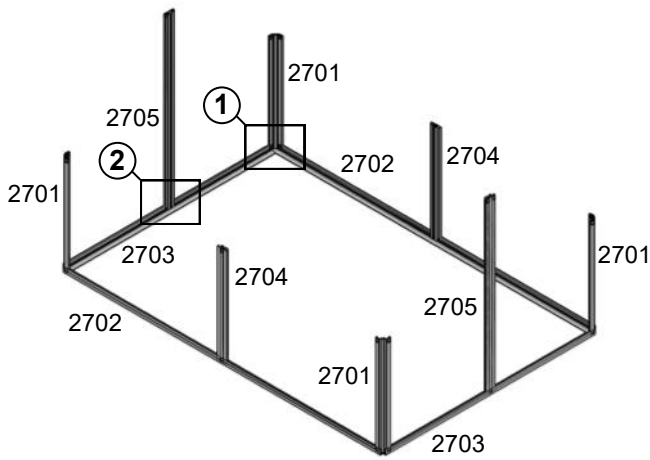
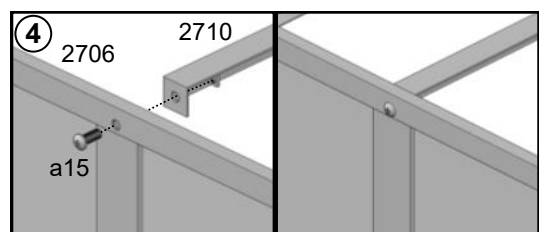

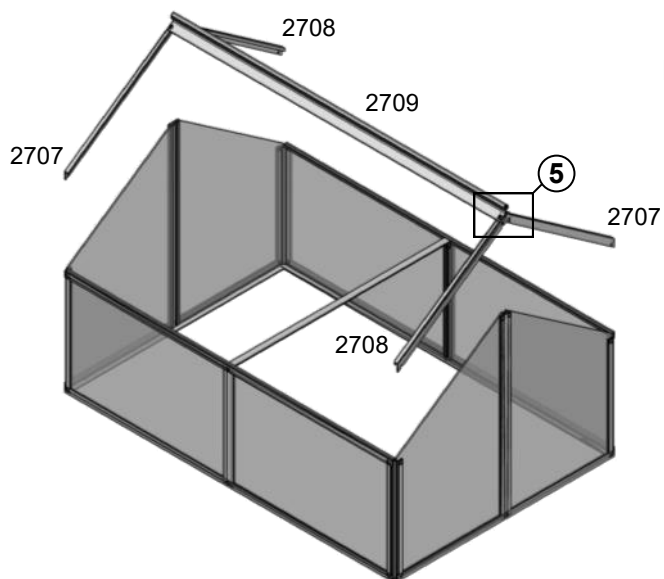

Note: Part #2707 & #2708 should be connected with part #2709 firstly, and then were fixed on the part #2701 & #2705.

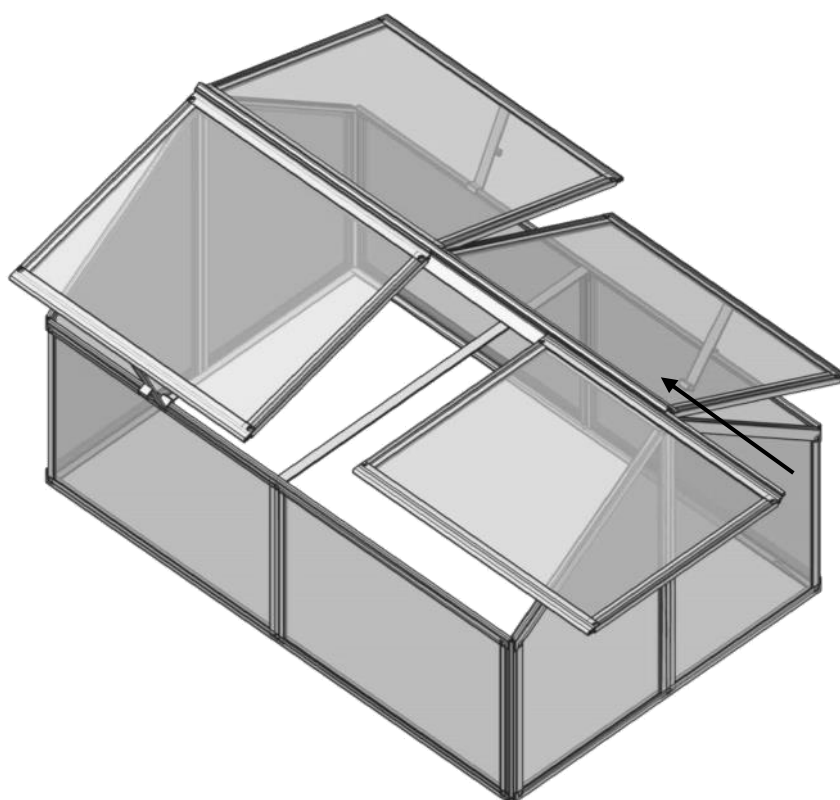
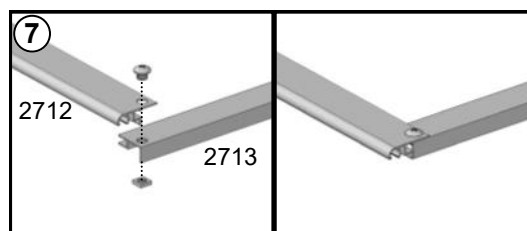
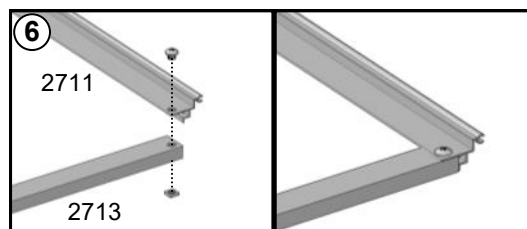
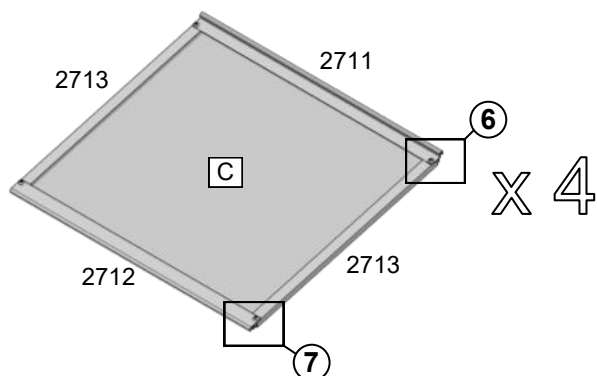
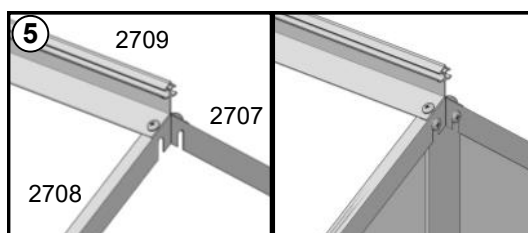

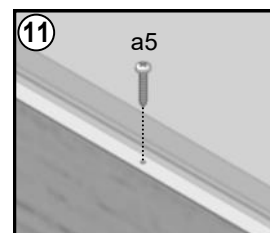
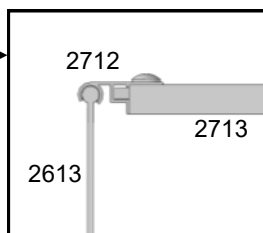
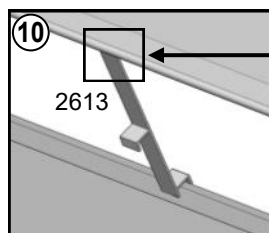
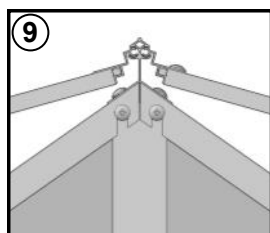
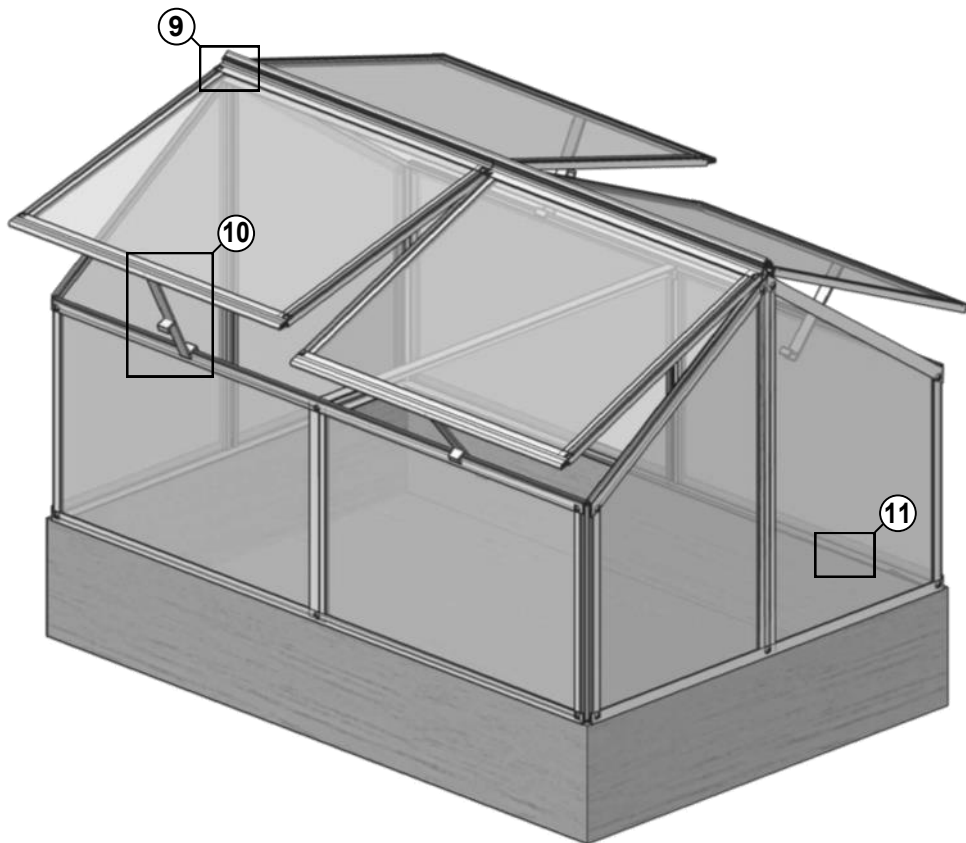

The list of Section

Part No.	Length (mm)	Drawing	QTY	Part No.	Length (mm)	Drawing	QTY
2701	364		4	2712	600		4
2702	1179		2	2713	466		8
2703	779		2	2613	20		4
2704	364		2	a7	M6x4.8		44
2705	629		2	a8	M6		46
2706	1179		2	a15	M6x15		2
2707	488		2	a5	Φ3.5x19		12
2708	488		2				
2709	1198		1	A	582x373	Polycarbonate panel	4
2710	819		1	B	382x373/637		4
2711	600		4	C	572x477		4