

# bestplay

Bestplay fodboldmål 300x200 cm

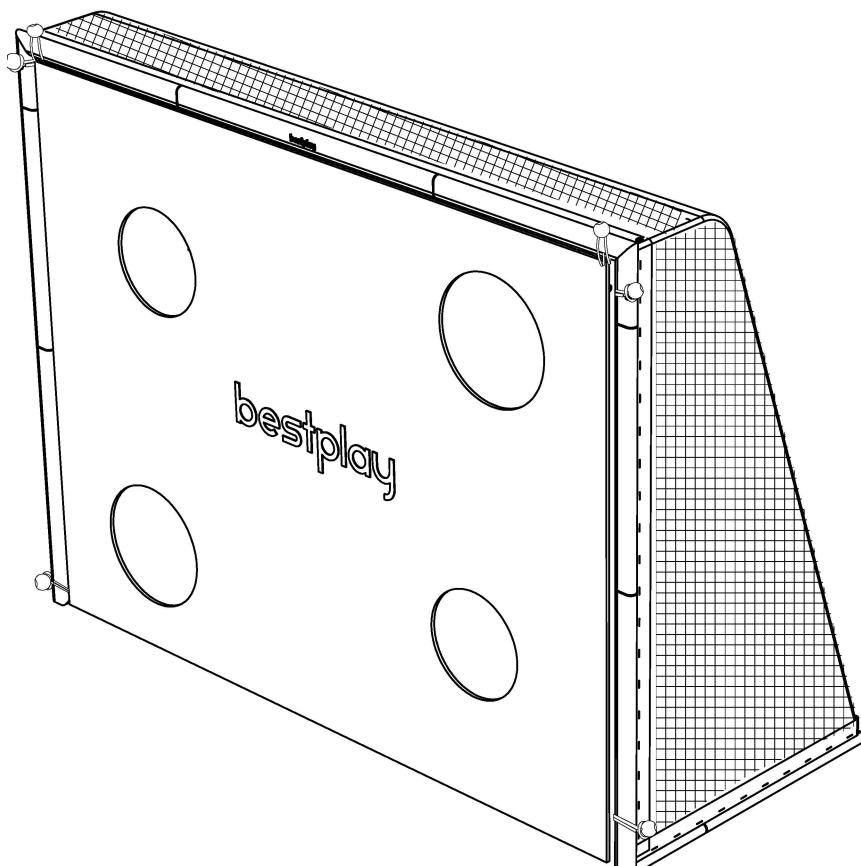

**ADVARSEL! Hvis du ikke følger alle instruktioner præcist, kan det medføre alvorlig personskade.**



## Sikkerhedsadvarsel

Læs alle instrukser og færdiggør samlingen før brug. Det kan være en fordel at være to til at samle fodboldmålet.

Hvis den er samlet og bruges korrekt, kan den bruges til mange timers sjov og træning.

Tjek fodboldmålet før hvert brug. Hvis dele er slidte, i stykker eller manglende, så udskift disse. Spænd dele der måtte være løse.

For at undgå at små børn risikerer at blive viklet ind i nettet, bør de holdes væk fra nettet. Hav altid opsyn af en voksen hvis børn bruger fodboldmålet.

Lad aldrig et barn klatre på fodboldmålet, da dette kan få det til at vælte og kan forårsage alvorlige skader på barnet.

Da metalrammen er elektrisk ledende, må elektriske dele aldrig komme i kontakt med fodboldmålet. Dette inkluderer bl.a. lamper, forlængerledninger og andet elektrisk udstyr.

## Samlingsadvarsel

Saml aldrig fodboldmålet i voldsomt regnvejr, blæst, storm eller lignende forhold.

Når fodboldmålet skal flyttes, bør mindst to personer med lige vægtfordeling løfte det.

Placer fodboldmålet på en plan overflade ved ethvert brug.

Frigør pladsen omkring fodboldmålet, så der ikke hænger ledninger, grene eller andre forhindringer i nærheden.

## Vedligeholdelse

Tjek fodboldmålet før ethvert brug.

Følgende forhold kan potentielt udgøre fare:

1. Manglende, forkert eller usikker samling af metalrammen.
2. Hvis nettet er hullet, flosset eller ødelagt.
3. Bøjet eller brækket metalramme.
4. Udstikkende skarpe dele.
5. Løse eller manglende dele af fodboldmålet.

## Monteringsdele

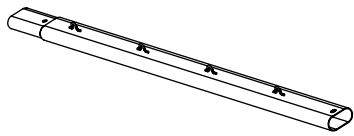

**1** Siderør A 4 stk.  
80020315

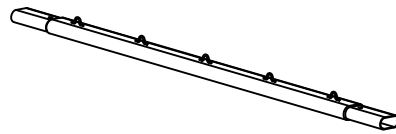
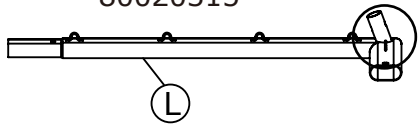

**2** Bagerste siderør B 1 stk.  
80020316

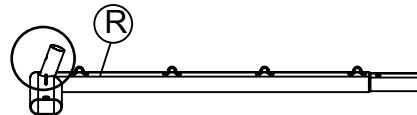

**3** Bagerste venstre bundrør L 1 stk.  
80020317



**4** Bagerste højre bundrør R 1 stk.  
80020318

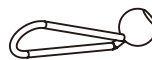

**5** Nederste forreste rør 2 stk.  
80020319

**6** Kugle med elastik 6 stk.  
80020150

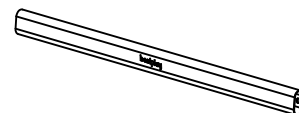
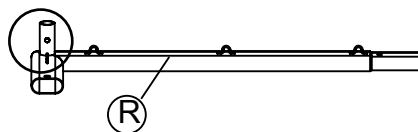
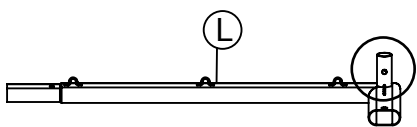

**7** Øverste venstre rør L 1 stk.  
80020320

**8** Øverste højre rør R 1 stk.  
80020321

**9** Toprør 1 stk.  
80020322

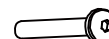
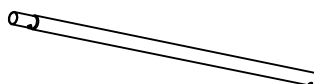
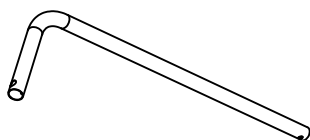

**10** Bagerste topør 2 stk.  
80020323

**11** Bagerste siderør 2 stk.  
80020324

**12** Bolt M8X40mm 4 stk.  
80020134

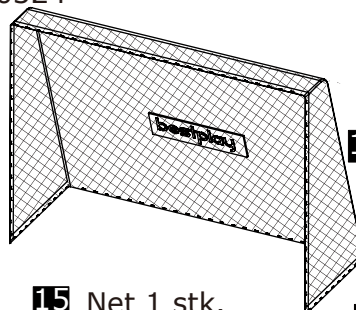

**13** Skive 4 stk.  
80020196

**14** Møtrik 4 stk.  
80020198

**16** Kort snor 2 stk.  
80020326

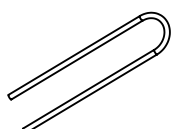

**18** Pløk 4 stk.  
80020133

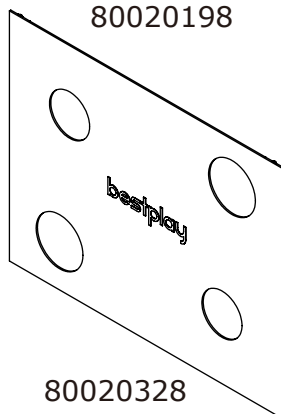

**19** Shooting target 1 stk.  
80020328

**15** Net 1 stk.  
80020325

**17** Lang snor 2 stk.  
80020327



**20** Værktøj 1 stk.  
80020132

## Trin 1

Tryk de to siderør A (1) ind på hver side af det bagerste siderør B (2) indtil trykknapperne klikker ind i hullerne som vist på tegningen.

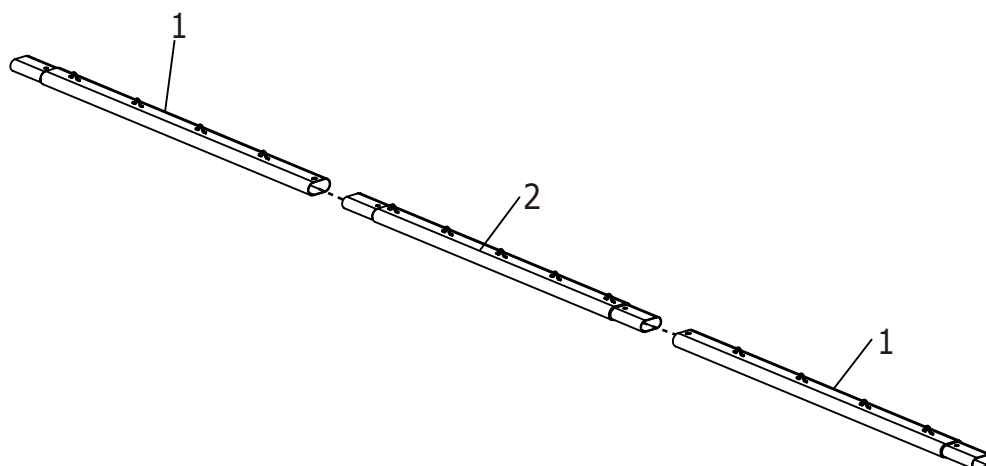

## Trin 2

Indsæt det bagerste venstre bundrør L (3) og det bagerste højre bundrør R (4) i begge sider på delen i trin 1 indtil trykknapperne klikker ind i hullerne som vist på tegningen.

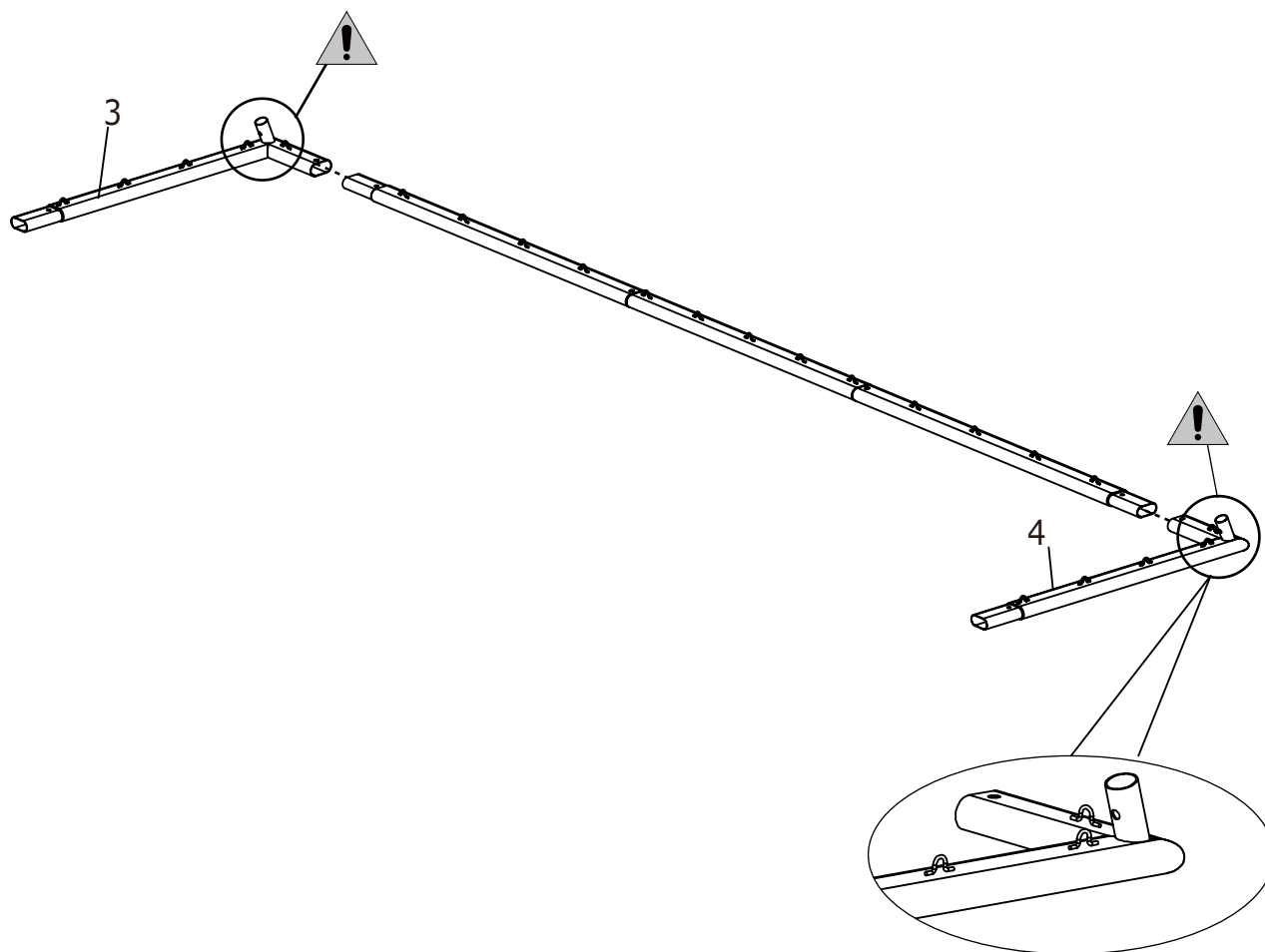

### Trin 3

Sæt det nederste forreste rør (5) ind i det bagerste venstre bundrør (3) og det bagerste højre bundrør (4) indtil trykknapperne klikker ind i hullerne som vist på tegningen.

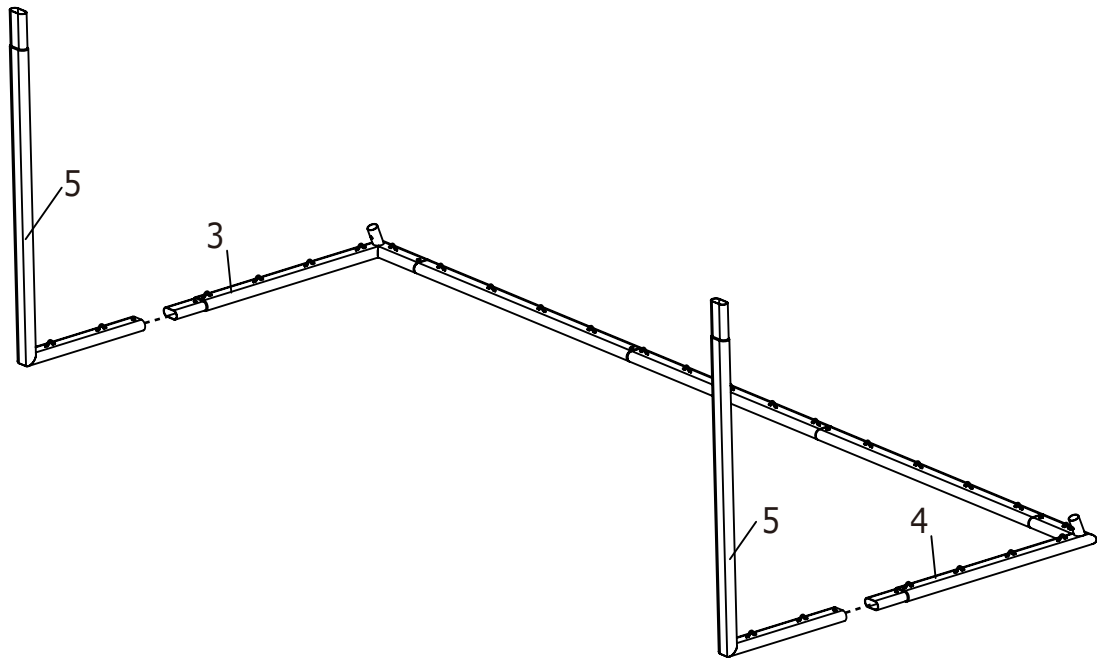

### Trin 4

Indsæt to siderør A (1) i den nederste forreste del (5) indtil trykknapperne klikker ind i hullerne som vist på tegningen.

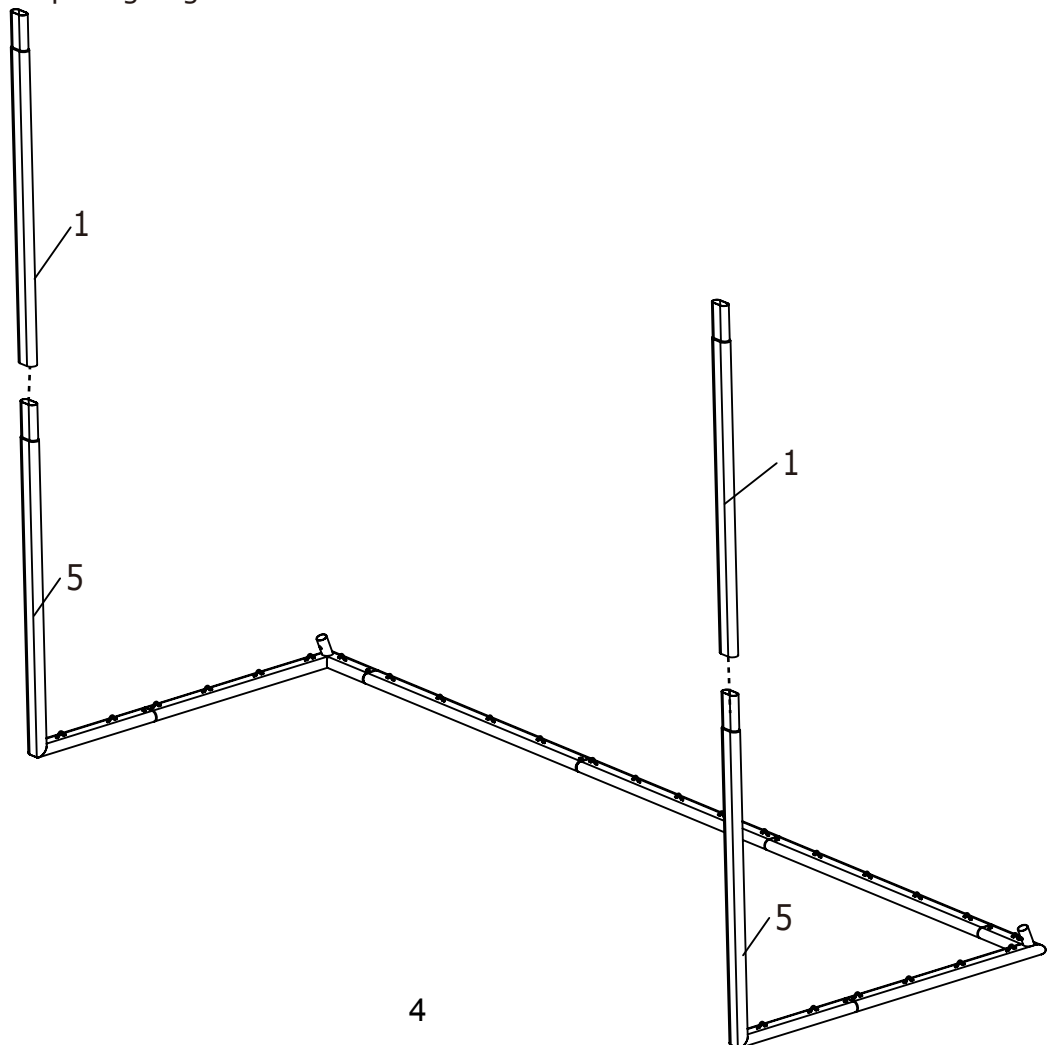

## Trin 5

Sæt det øverste venstre L-rør (7) og det øverste højre L-rør (8) ind i det øverste top rør (9) indtil trykknapperne klikker ind i hullerne som vist på tegningen.

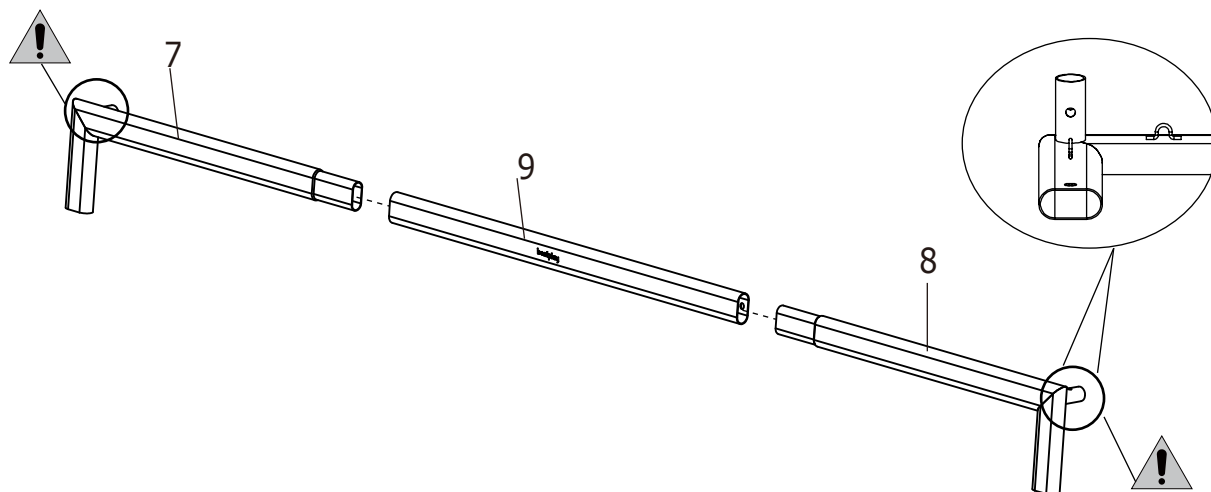

## Trin 6

Sæt nu delene i trin 5 sammen med delene i trin 4 indtil trykknapperne klikker ind i hullerne som vist på tegningen.

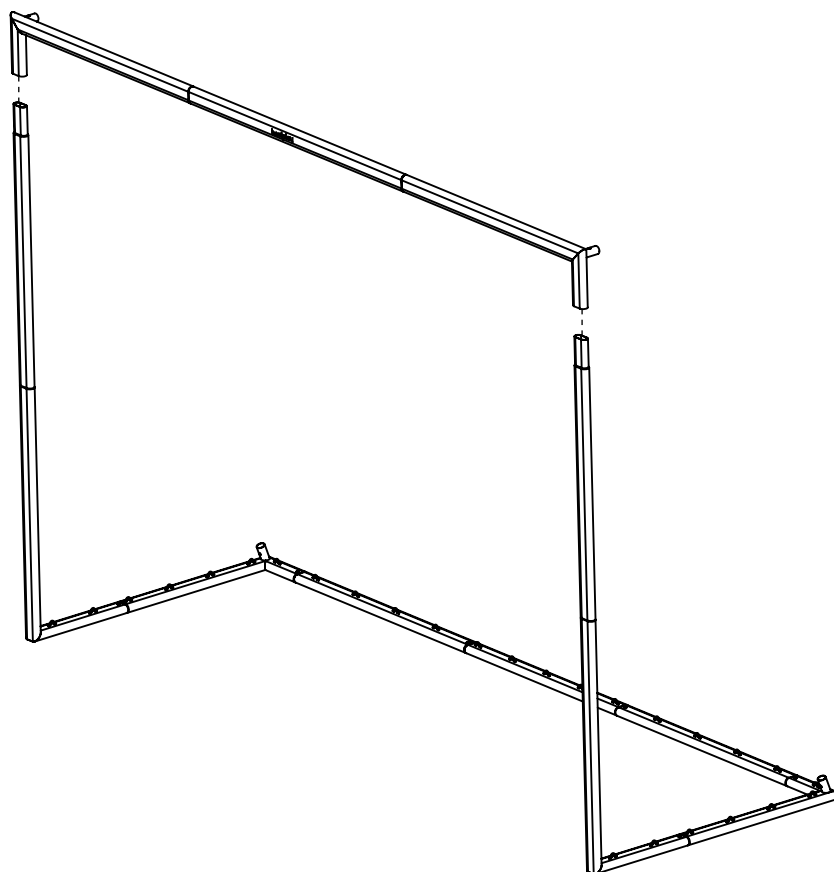

## Trin 7

Sæt det bagerste toprør (10) ind i det bagerste siderør (11) indtil trykknapperne klikker ind i hullerne som vist på tegningen.

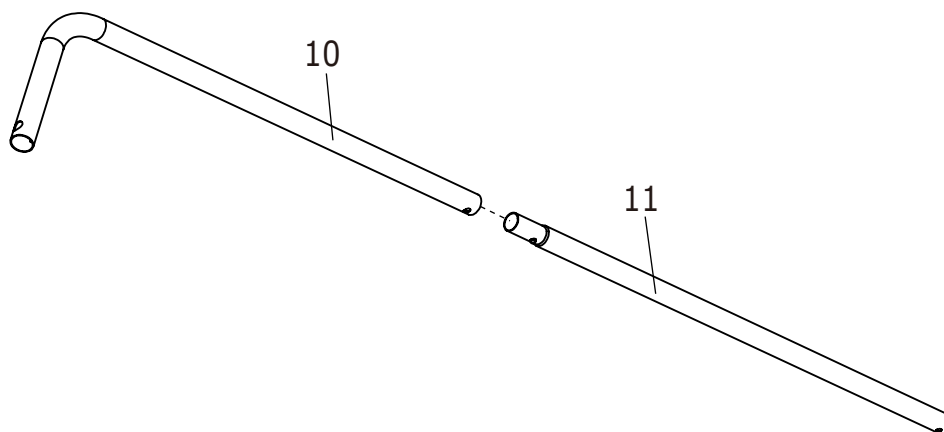

## Trin 8

Fastgør det bagerste toprør (10) til det øverste venstre L-rør (7) og det øverste højre L-rør (8) med to M8X40mm-bolte (12), to M8-skiver (13) og to M8-møtrikker (14).

Fastgør det bagerste siderør (11) til det bagerste venstre bundrør (3) og det bagerste højre bundrør (4) med to M8X40mm-bolte (12), to M8-skiver (13) og to M8-møtrikker (14).

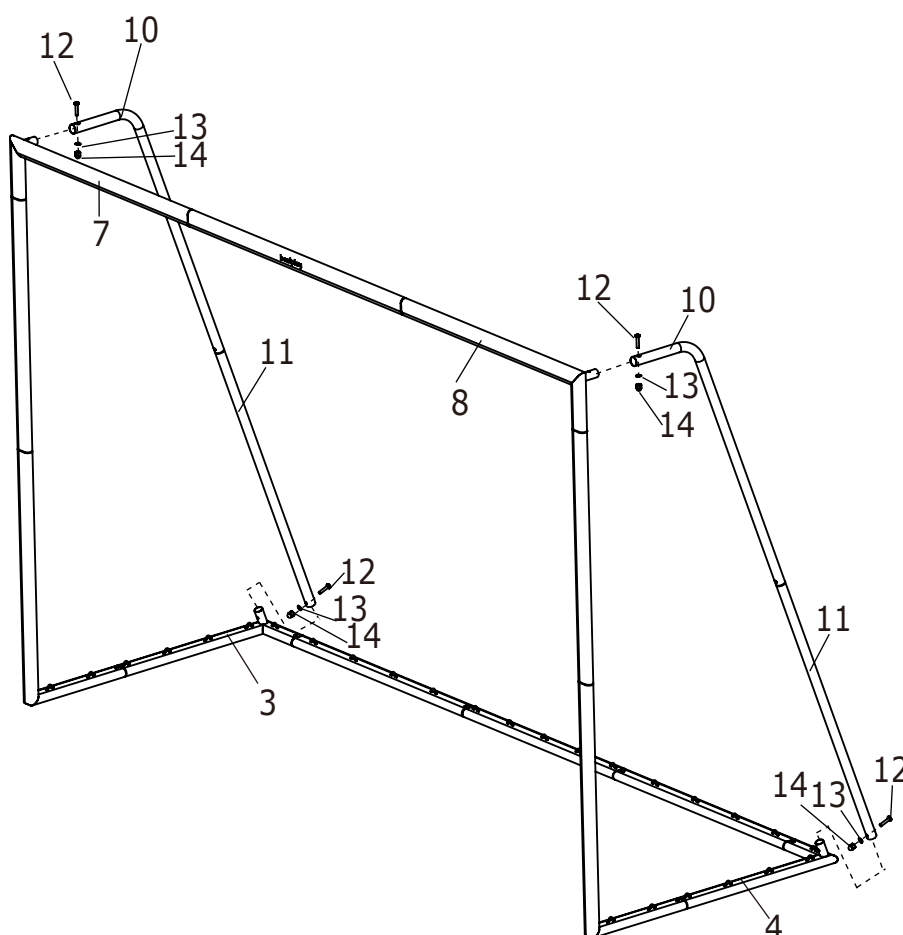

## Trin 9

Sæt fodboldmålet fast ved brug af de 4 pløkker (18) som vist.

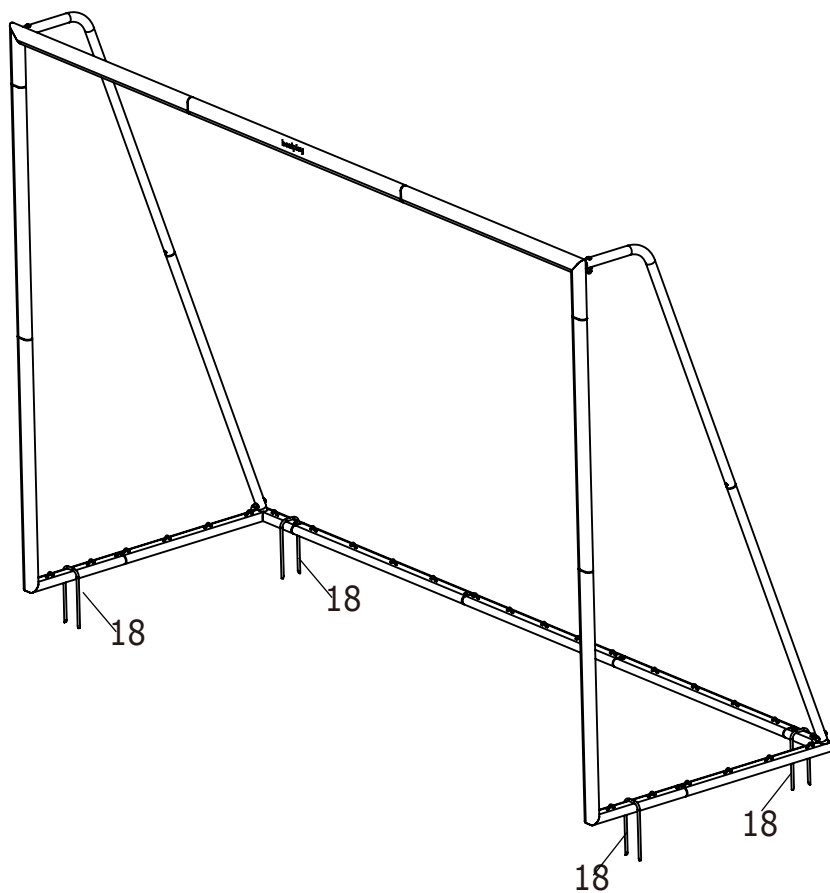

## Trin 10

Placér nettet (15) på rammen.

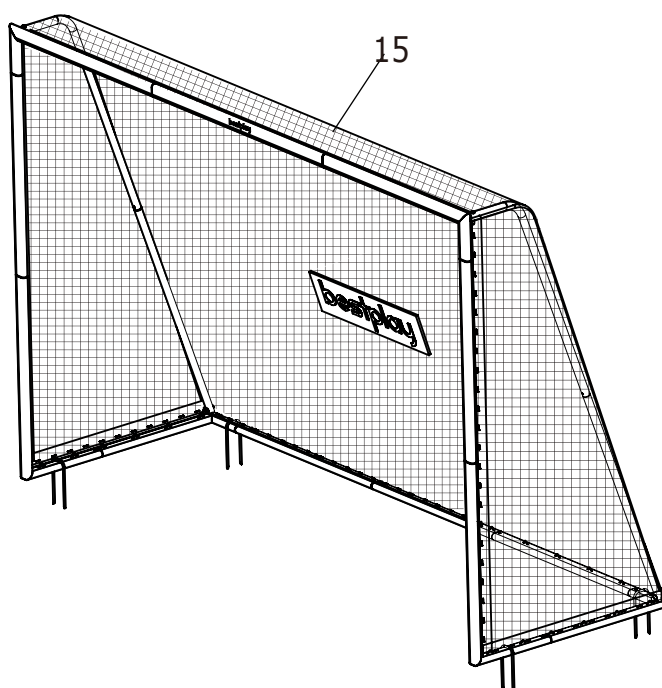



## Trin 11

Før den korte snor (16) gennem den første ring på rammen øverst og derefter gennem det første hul i nettet (15). Fortsæt indtil alle huller og ringe er samlet.

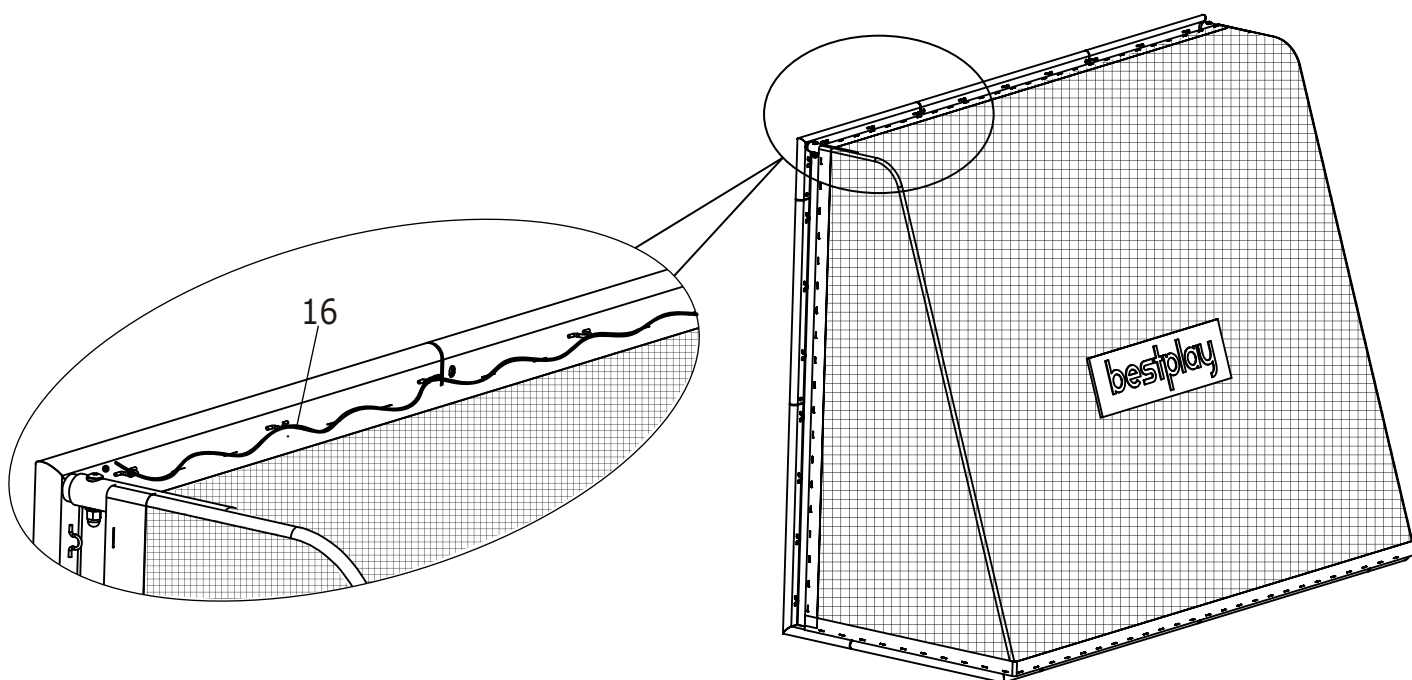

## Trin 12

Før den lange snor (17) gennem den første ring på siden af rammen og derefter gennem det første hul i nettet (15). Fortsæt indtil alle huller og ringe er samlet.

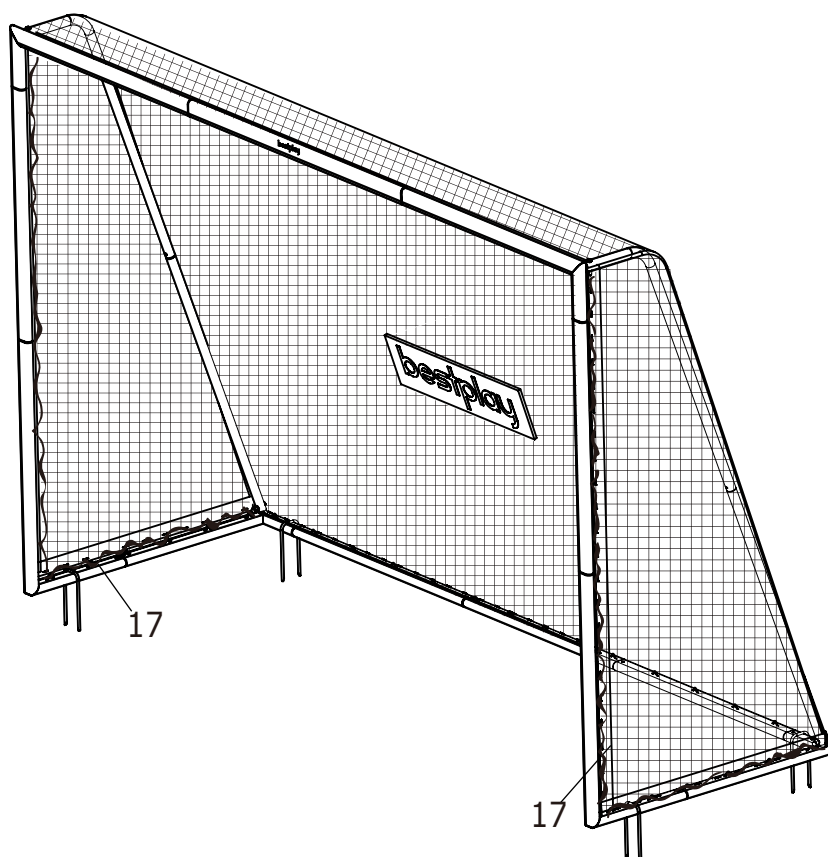

### Trin 13

Før den korte snor (16) gennem den første ring nederst på rammen og gennem det første hul i nettet (15). Fortsæt indtil alle huller og ringe er samlet.

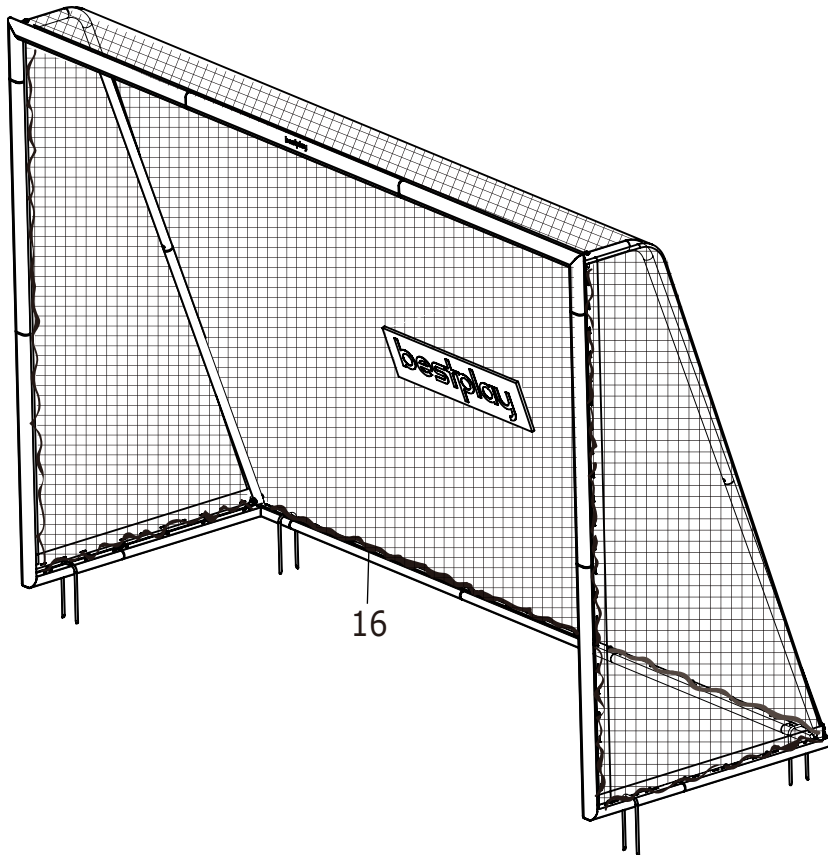

### Trin 14

Saml snoren op og bind den på samme måde, som det er vist.

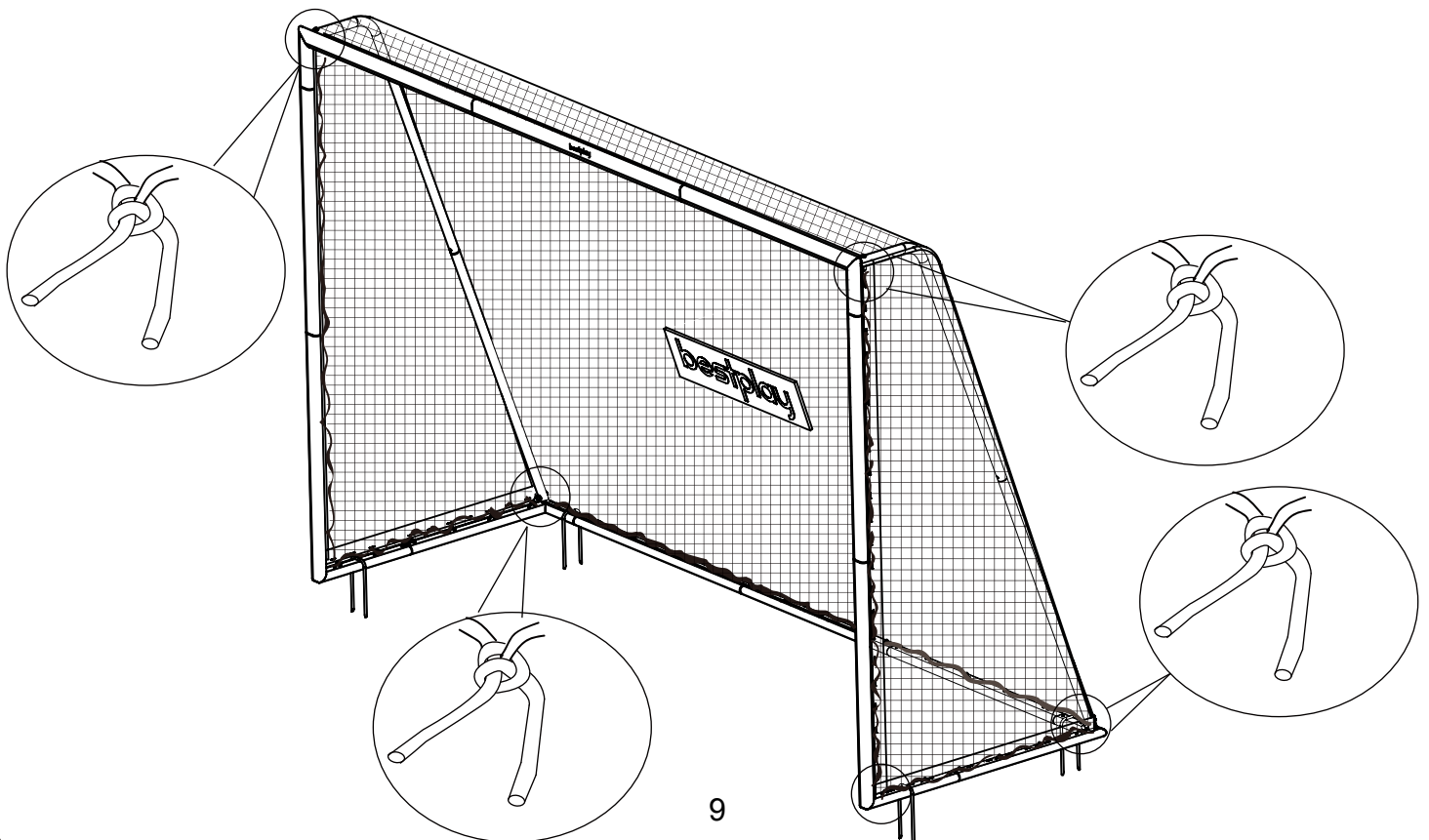

## Trin 15

Hvis du vil opbygge flere færdigheder, skal du følge nedenstående trin for at installere shooting target (19). Placér forsiden af trænings-skærmen med logoet der peger ud mod dig selv og sæt elastikker med kugler (6) i hvert hjørne. Løft elastikkerne med kugler (6) gennem stropen og rammen som vist.

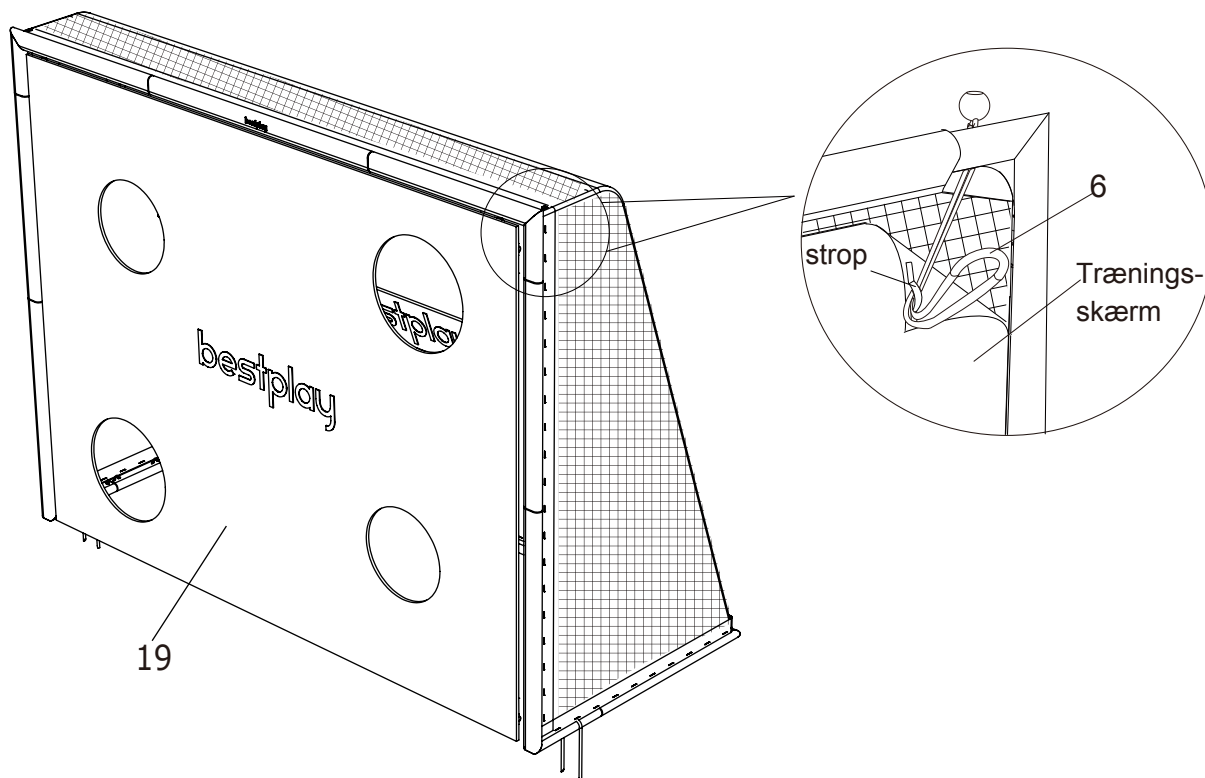

## Trin 16

Gentag trin 15 for at fastgøre de resterende elastikker med kugler (6) som vist.

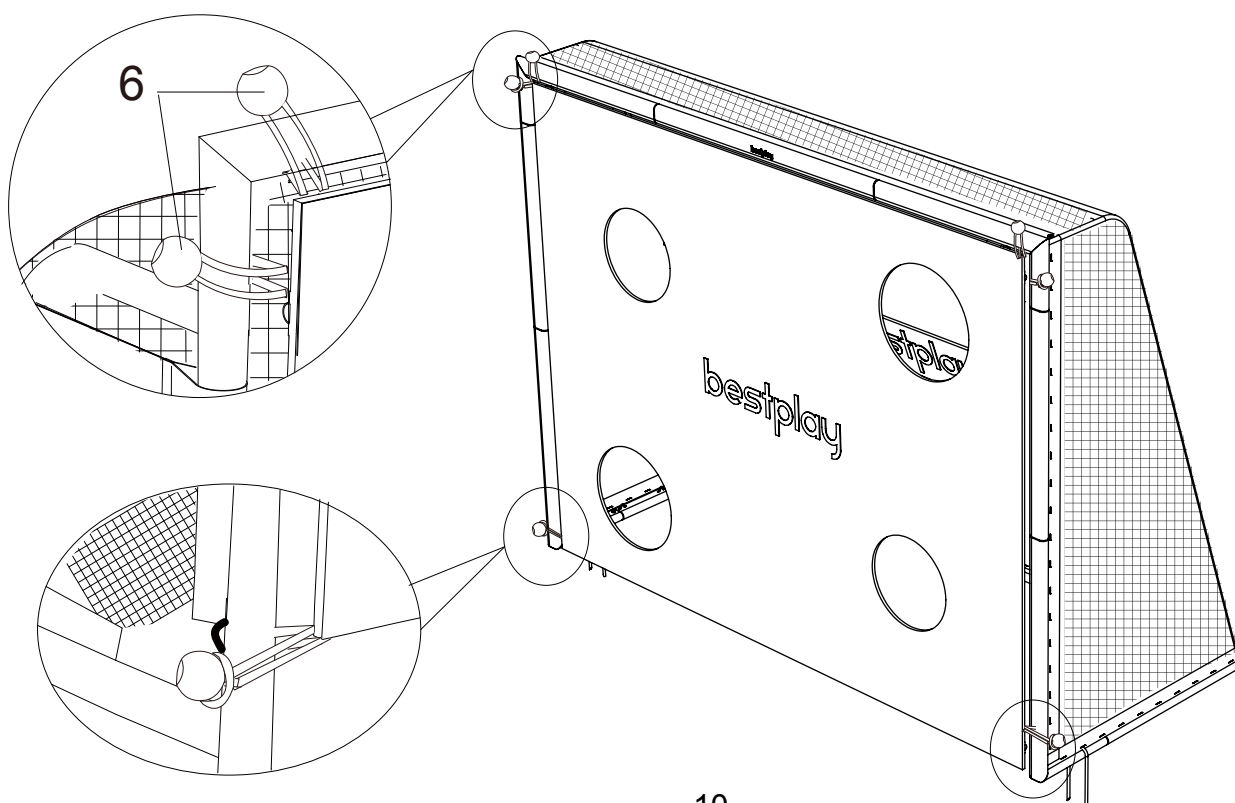



Bestplay football goal 300x200 cm

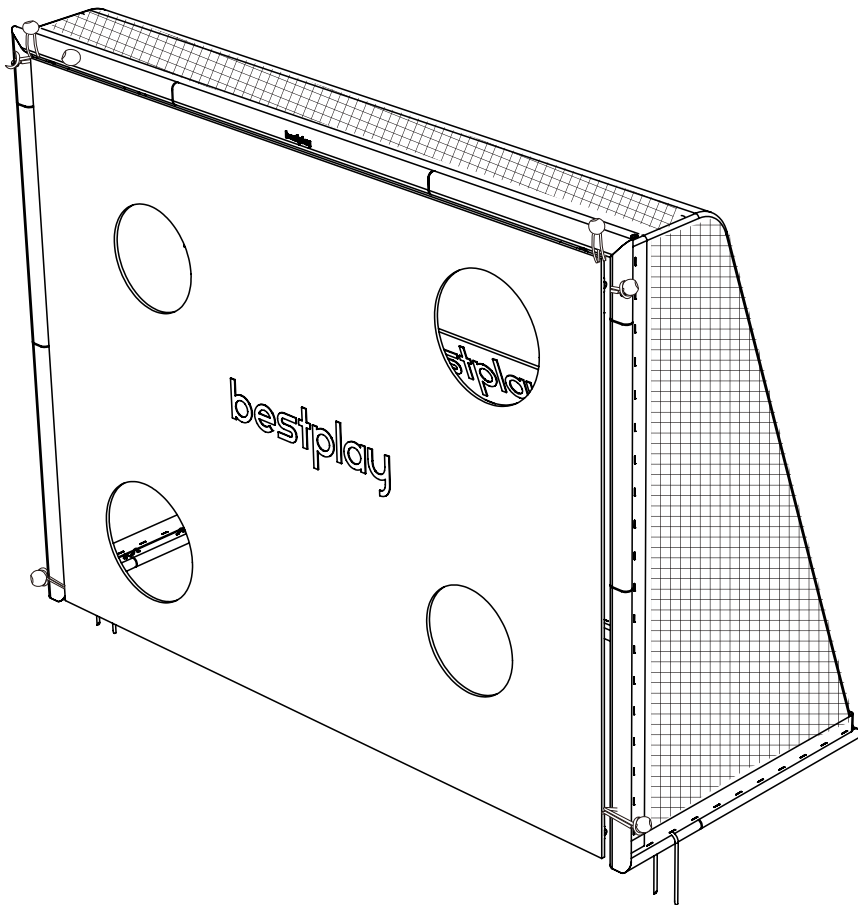

**WARNING! Please follow all instructions. Failure to follow all instructions can result in serious injury.**



## Safety warning

Read all instructions and complete assembling the product before use.

Never let children climb on the product as this can result in product tipping over causing serious injuries to the child.

Adult supervision is necessary at all times when the product used by children.

To reduce risk of entanglement in the net, keep small children away from net area at all times.

When properly assembled and used as intended, this product is designed to provide many hours of training and fun.

The metal frame of the product can conduct electricity. Lights, extension cords, and all such electrical equipment must never be allowed to come in contact with the product.

Inspect the product before every use. Make sure all parts are correctly and securely positioned and attached. Tighten any loose parts. Replace any torn, defective, or missing parts.

## Assembly warnings

It is recommended to be two persons or more to assemble the product.

Clearance from all nearby objects is essential.

Place the product away from walls, structures and fences. Maintain a clear space on all sides of the product. A minimum of 3 meters from the sides of the product is recommended.

Move all obstacles such as wires, tree limbs, and other possible obstacles.

Never set up the product in heavy rain, wind or stormy conditions.

When moving the assembled product, have minimum two people to lift the product off the ground with even weight distribution.

Place the product on an even surface before use.

Secure the product against unauthorized and unsupervised use.

## Maintenance

Inspect the product before each use and replace any torn, defective, or missing parts.

The following conditions could present potential dangers:

1. Missing, wrongly positioned, or insecurely attached frame or frame padding.
2. Punctures, frays, tears, or holes worn in the product mesh.
3. A bent or broken frame or support system.
4. Sharp points sticking out of the frame or suspension.
5. Loosened or missing hardware.

# Part List

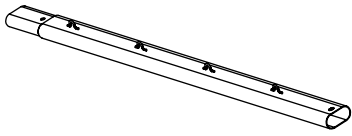

**1** Side Tube A 4 pcs.

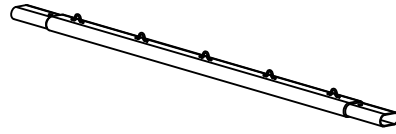

**2** Back Side Tube B 1 pcs.

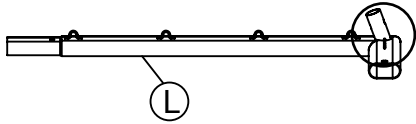

**3** Back Left Bottom Tube 1 pcs.

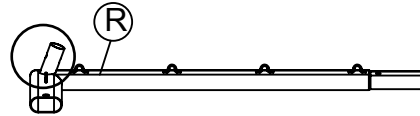

**4** Back Right Bottom Tube 1 pcs.



**5** Front Lower Tube 2 pcs.

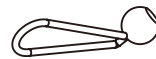

**6** Elastic with ball 6 pcs.

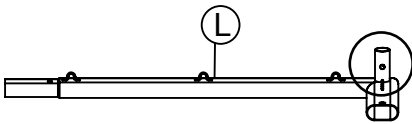

**7** Upper Left L Tube 1 pcs.

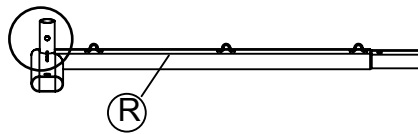

**8** Upper Right L Tube 1 pcs.

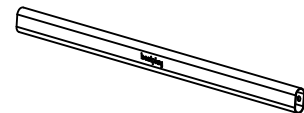

**9** Top Cross Beam 1 pcs.

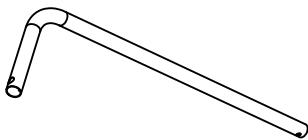

**10** Back Top Bent Tube 2 pcs.

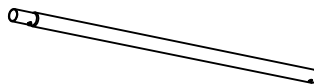

**11** Back Side Tube 2 pcs.

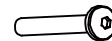

**12** M8X40mm Bolt 4 pcs.



**13** Washer 4 pcs.



**14** Nut 4 pcs.

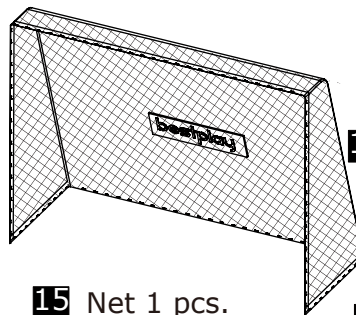

**15** Net 1 pcs.



**16** Short Rope 2 pcs.



**17** Long Rope 2 pcs.

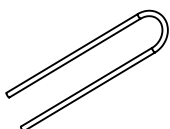

**18** Anchor 4 pcs.

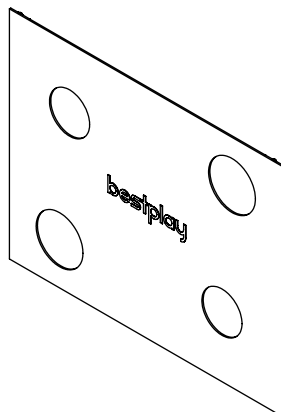

**19** Training Screen 1 pcs.



**20** Tool 1 pcs.

## Step 1

Press two Side Tube A (1) into the Back Side Tube B (2) until the push buttons snap into place as shown.

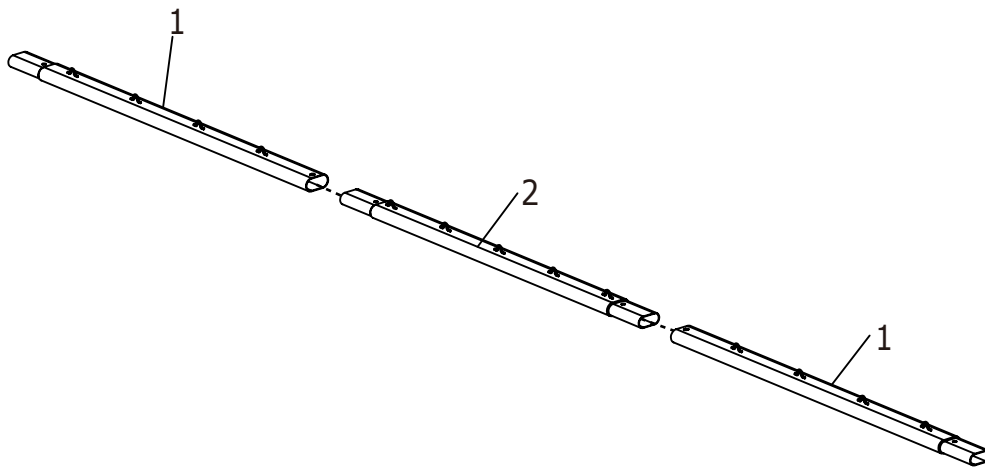

## Step 2

Insert the Back Left Bottom Tube (3) and Back Right Bottom Tube (4) into the step 1 until the button snap into the place as shown.

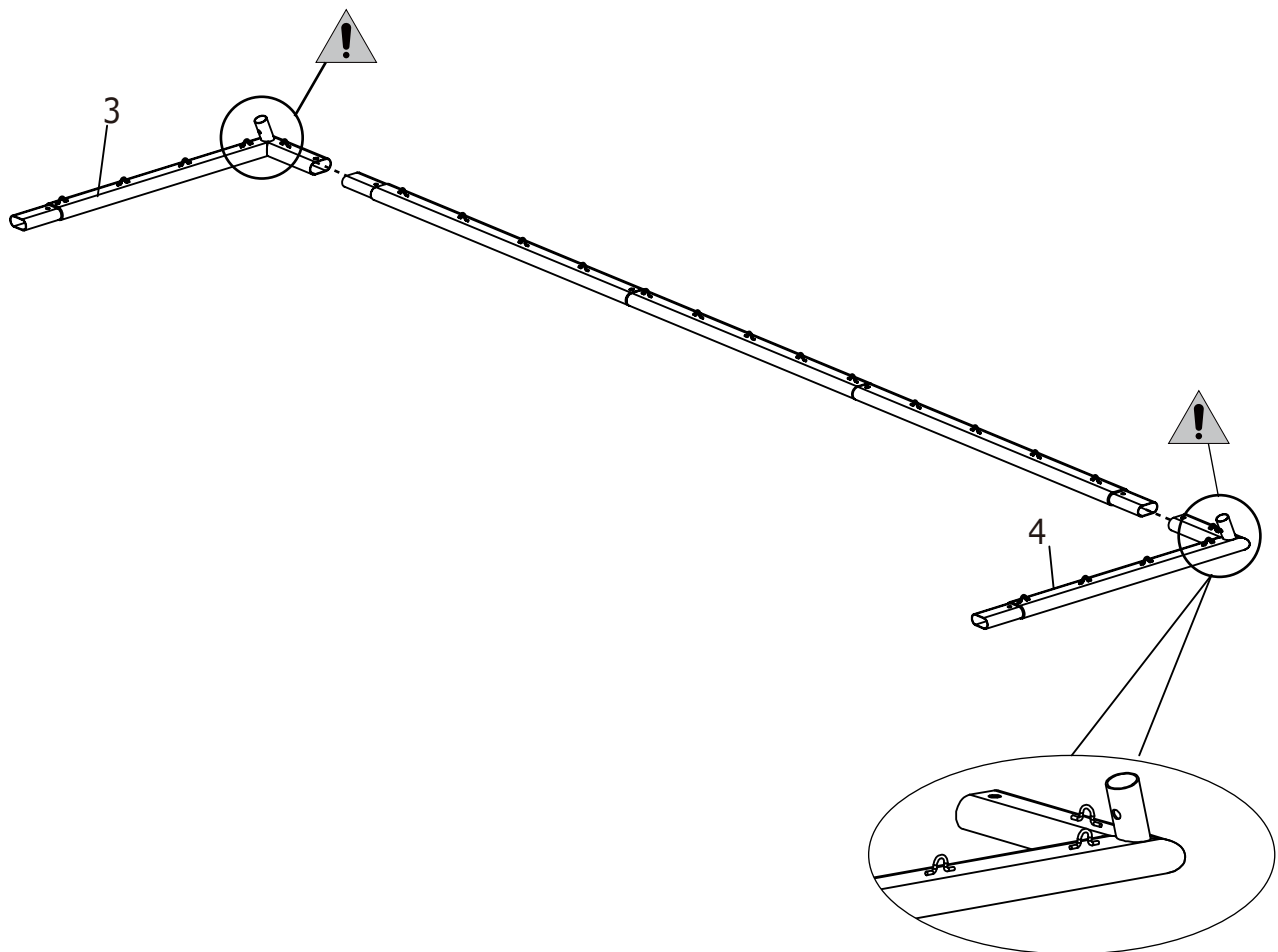

### Step 3

Insert the Front Lower Tube (5) into the Back Left Bottom Tube (3) and Back Right Bottom Tube (4) until the button snap into the place as shown.

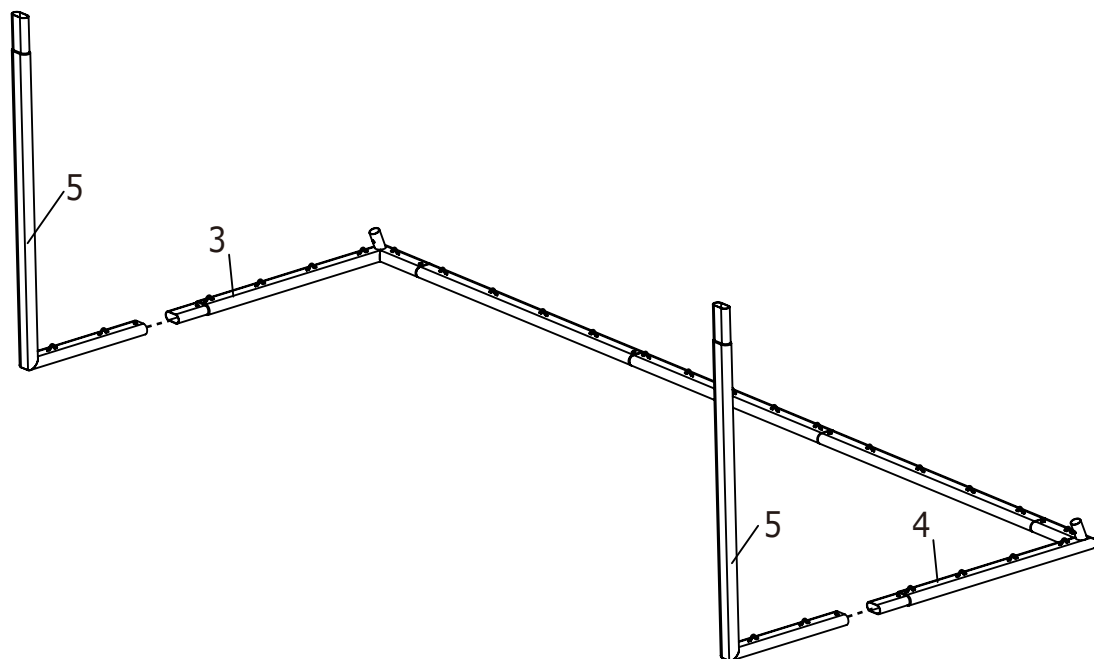

### Step 4

Insert two Side Tube A (1) into the Front Lower Tube (5) until the button snap into the place as shown.

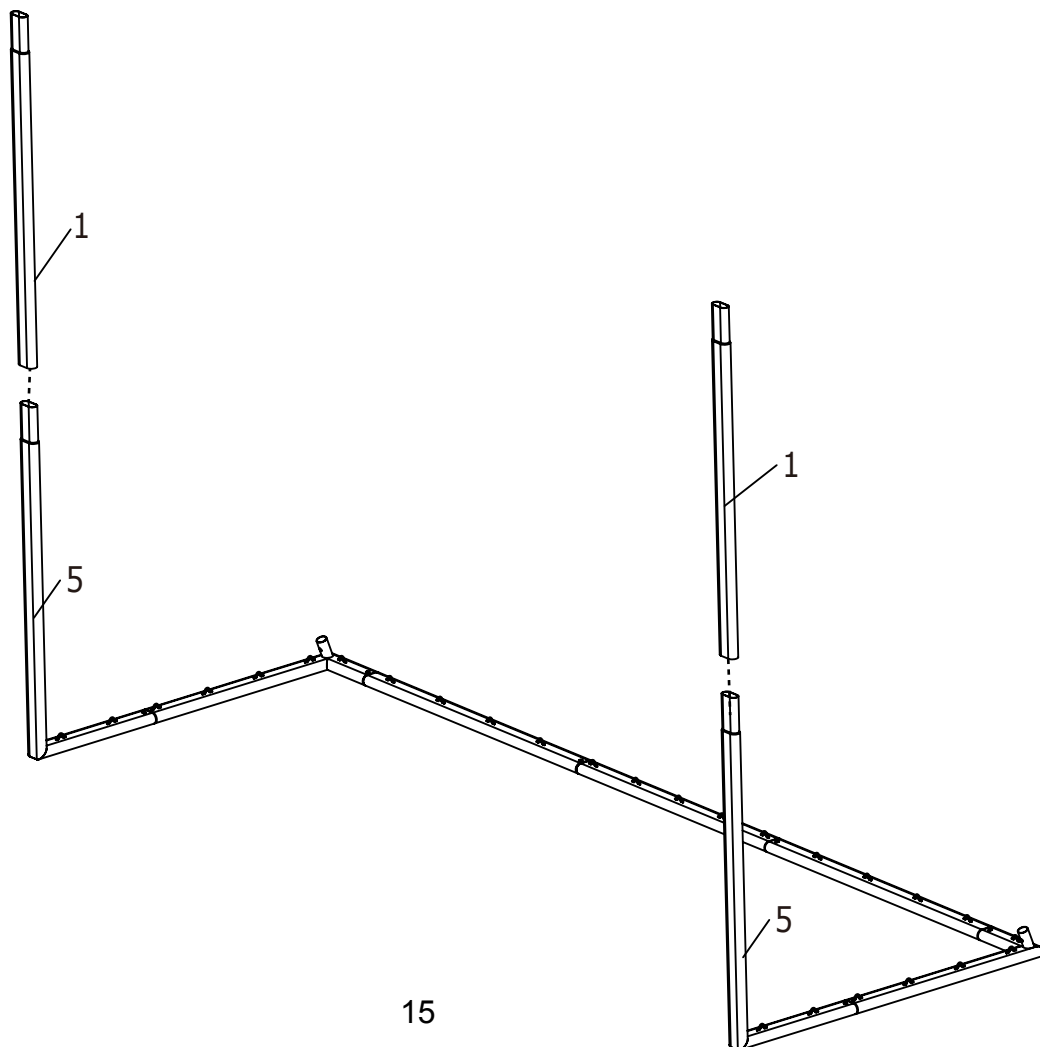



## Step 5

Insert the Upper Left L Tube (7) and Upper Right L Tube (8) into the Top Cross Beam (9) until the button snap into the place as shown.

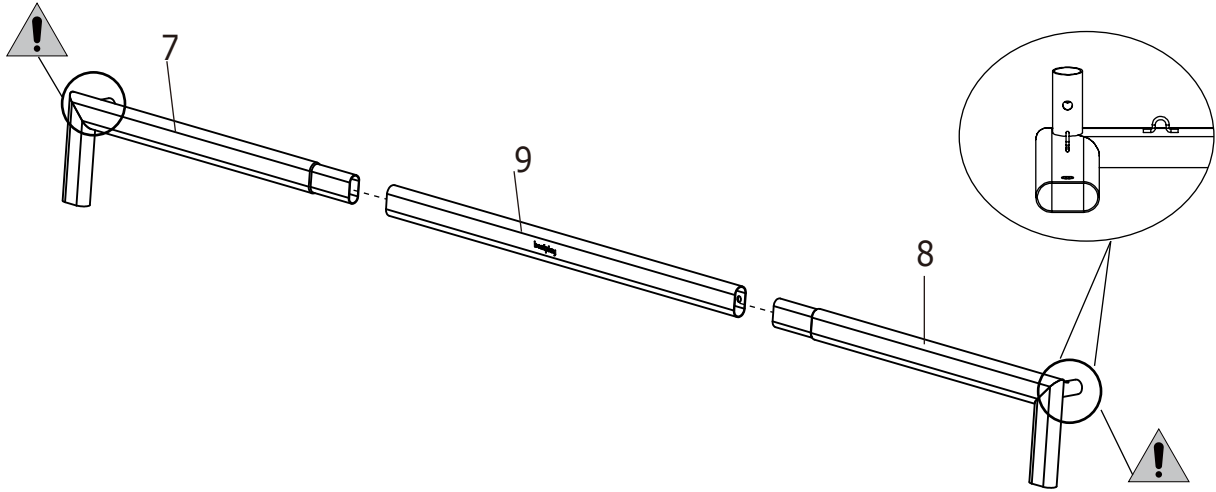

## Step 6

Insert the assembly step (5) into the assembly step (4) until the button snap into the place as shown.

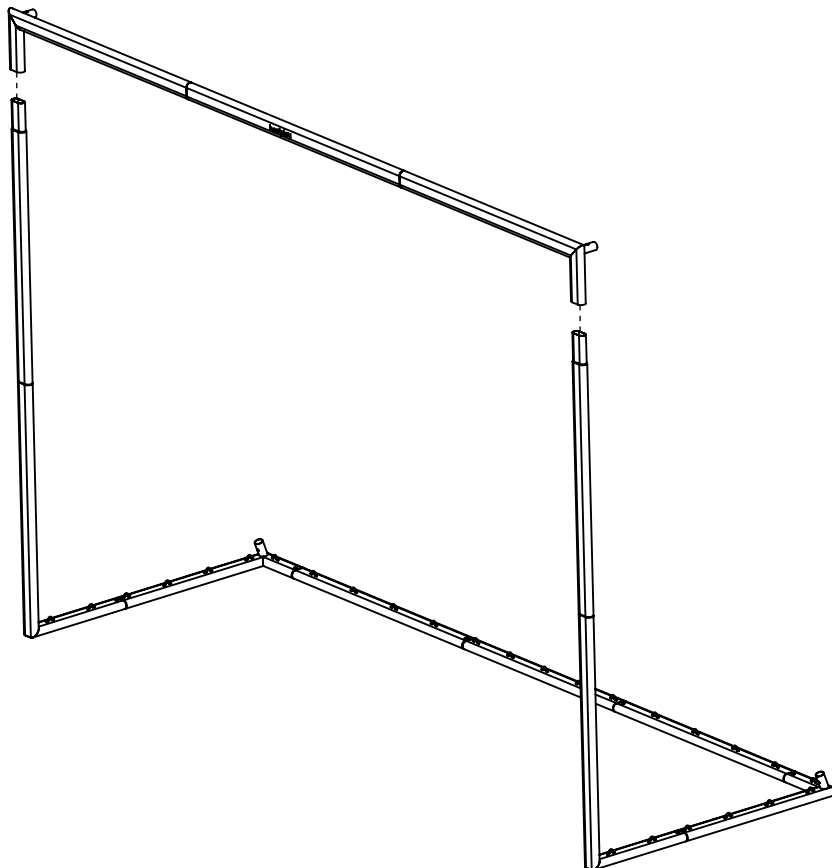

## Step 7

Insert the Back Top Bent Tube (10) into the Back Side Tube (11) until the button snap into the place as shown.

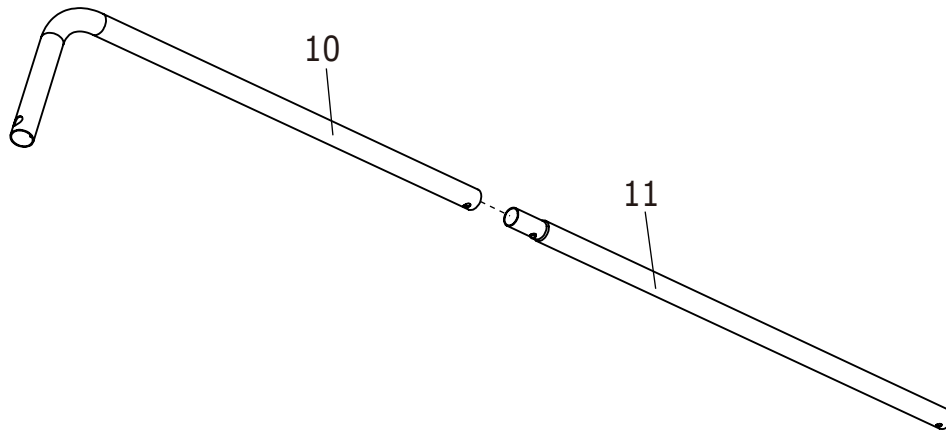

## Step 8

Attach the Back Top Bent Tube (10) to the Upper Left L Tube (7) and Upper Right L Tube (8) with two M8X40mm Bolts(12), two M8 Washes (13) and two M8 Nuts (14).

Attach the Back Side Tube (11) to the Back Left Bottom Tube (3) and Back Right Bottom Tube (4) with two M8X40mm Bolts(12), two M8 Washes (13) and two M8 Nuts (14).

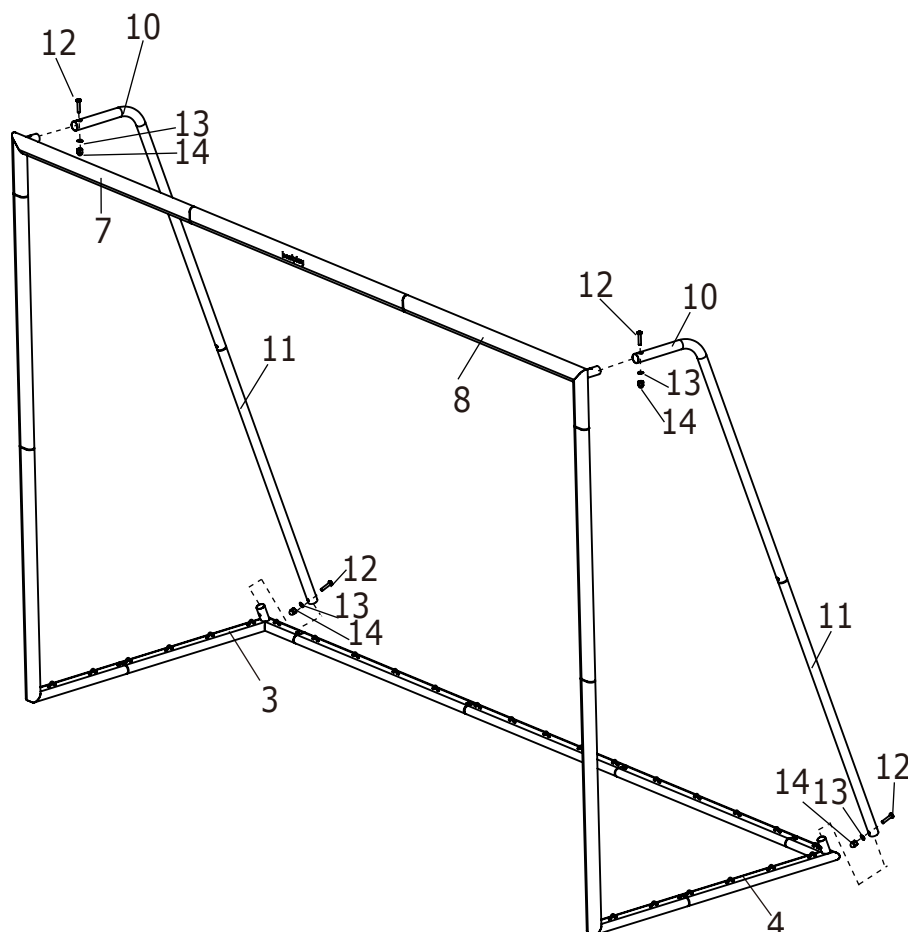

### Step 9

Using the anchor (18) fixed.

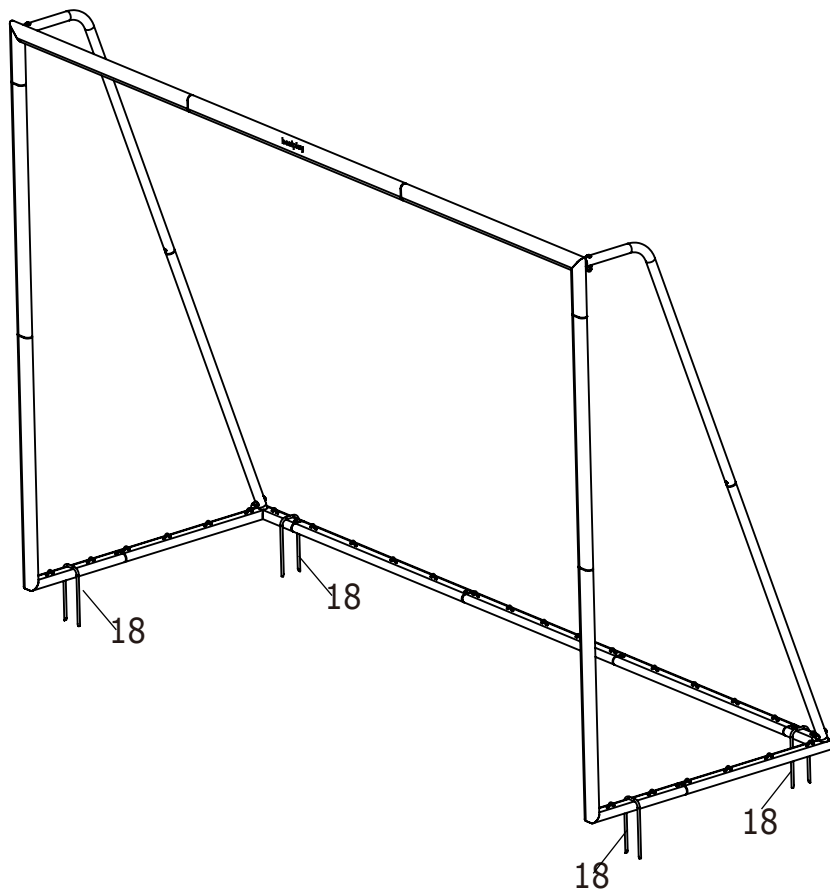

### Step 10

Please place the Net (15) on the frame.

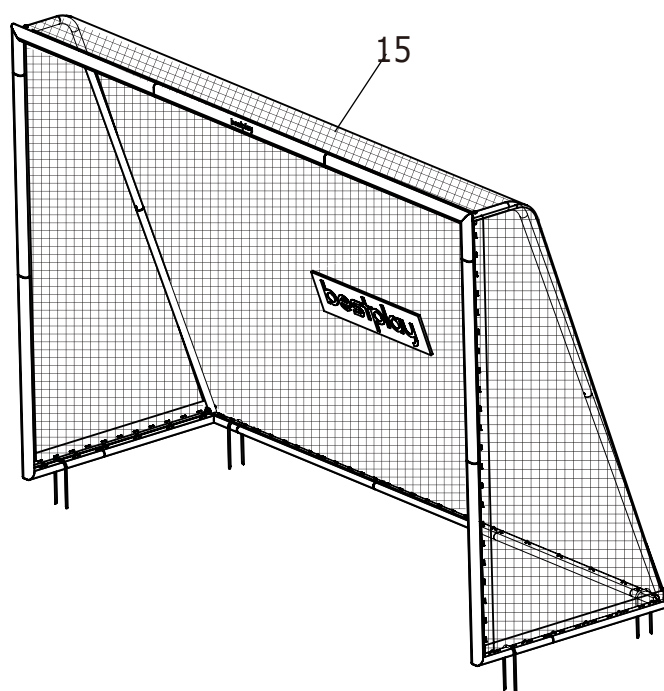

## Step 11

Use the Short Rope (16) through the first hoop of the Top frame, then through the first hole of the Net (15), and so on, until all the holes and hoops are assembled.

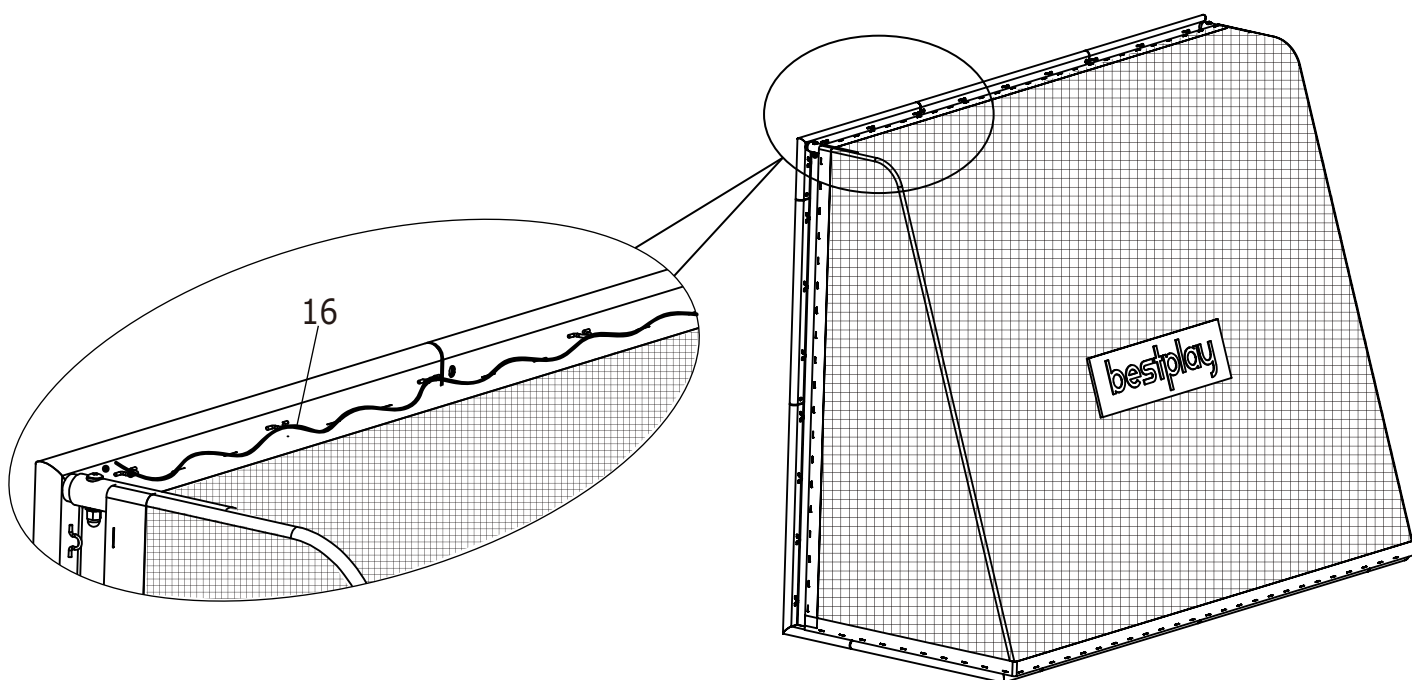

## Step 12

Use the Long Rope (17) through the first hoop of the side frame, then through the first hole of the Net (15), and so on, until all the holes and hoops are assembled.

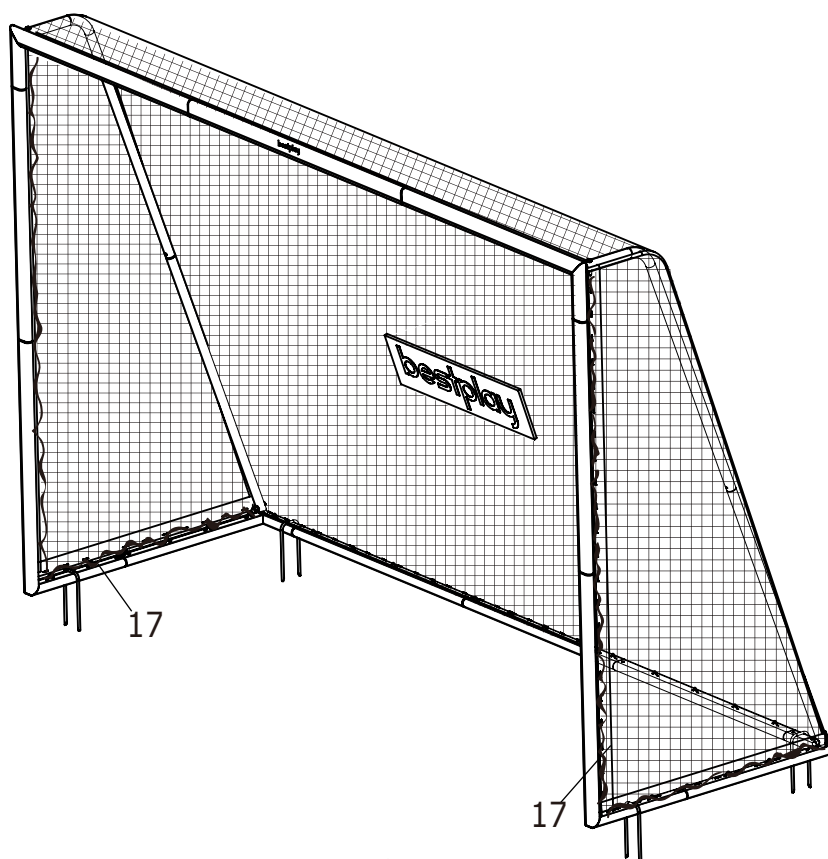

### Step 13

Use the Short Rope (16) through the first hoop of the bottom frame, then through the first hole of the Net (15), and so on, until all the holes and hoops are assembled.

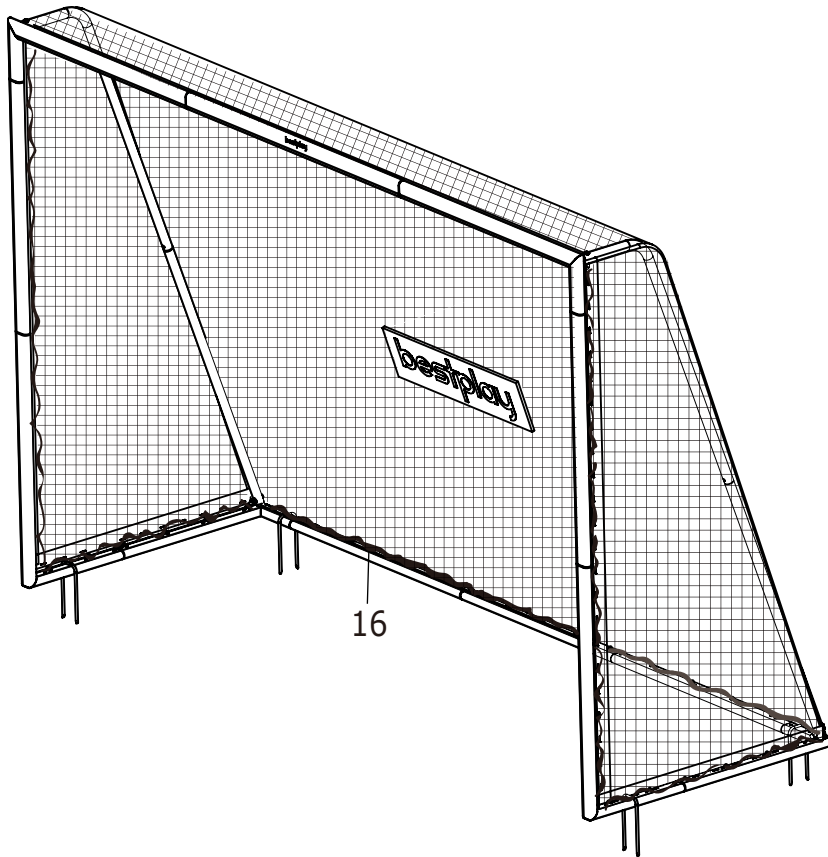

### Step 14

Pick up the end of the Rope, then tie it as shown.

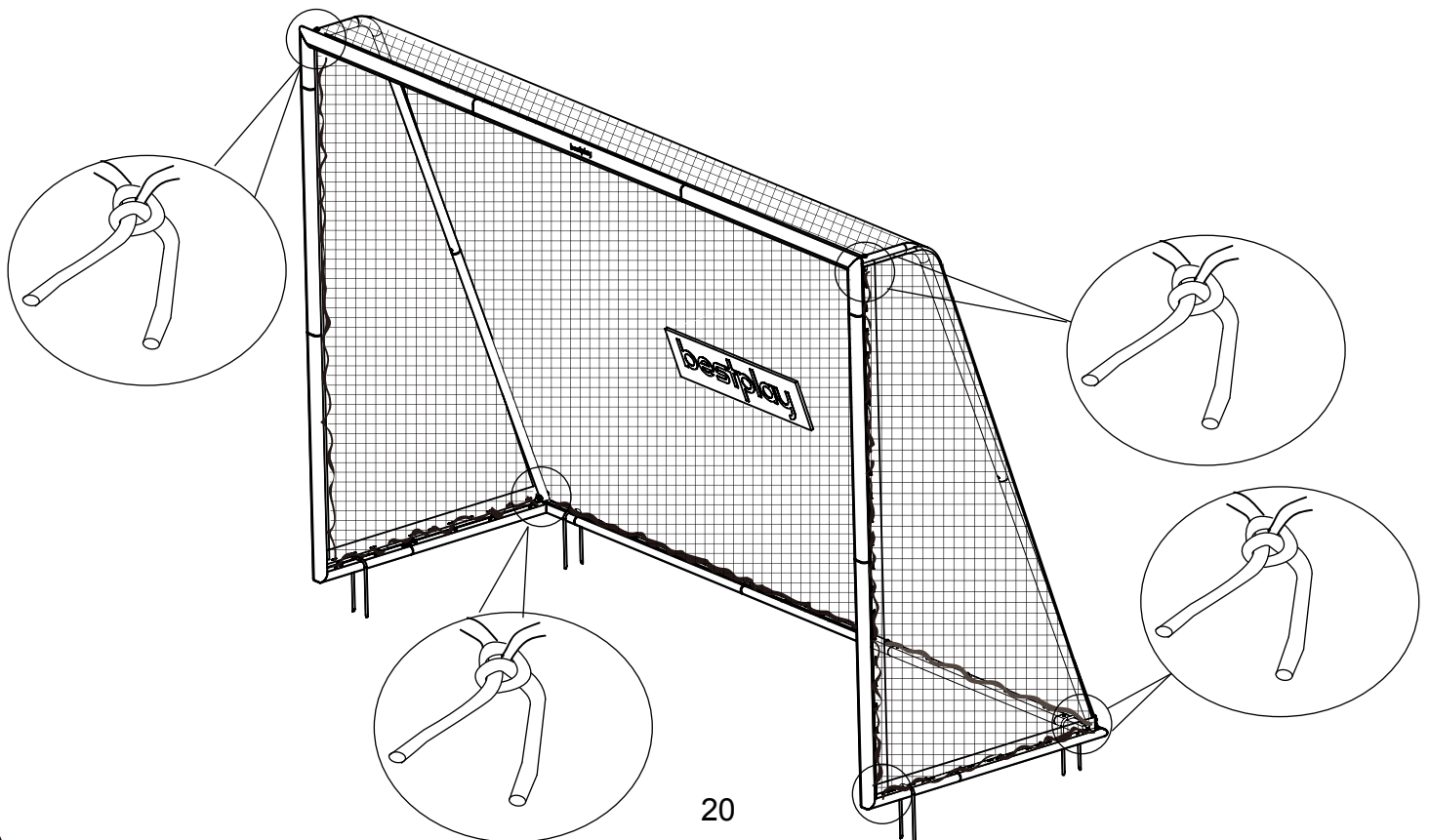

## Step 15

If you want to built more skills ,please follow the below steps to install Training Screen (19). Firstly make out the front surface of Training Screen with logo, and the back surface with straps at each corner. Then loop one Elastic with ball (6) through the strap and tube as shown and attach itself.

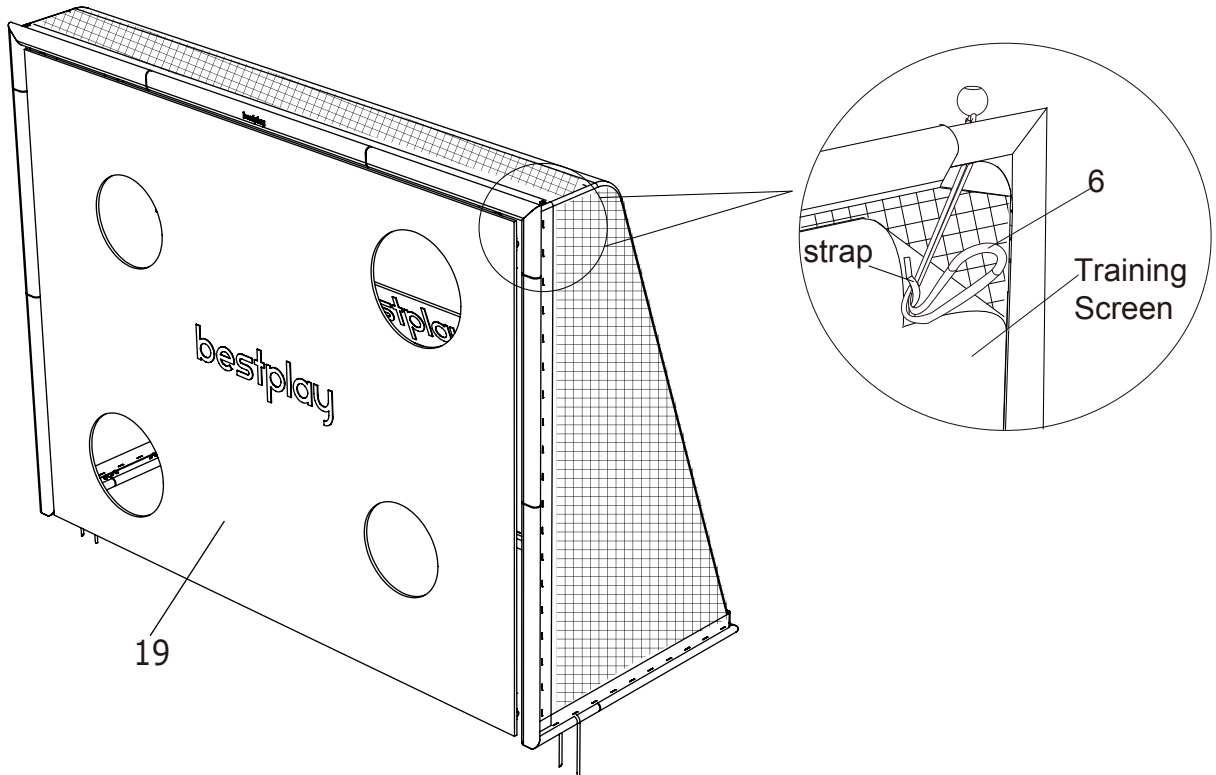

## Step 16

Repeat above step to attach remaining Elastics with ball (6) as shown.

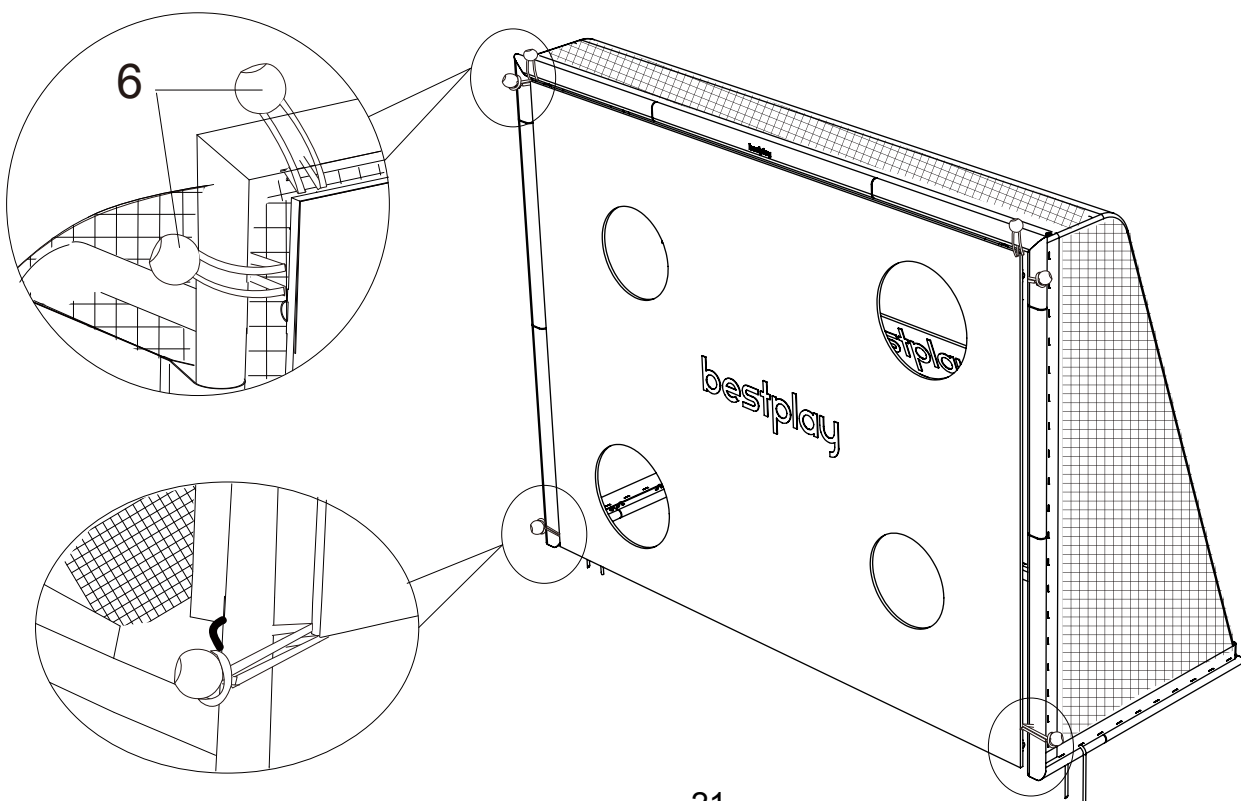





**Bestplay A/S  
Knullen 22  
5260 Odense S  
Tlf.: + 45 70 22 72 92**